

82-100/82A-140 SERIES

Bronze 3-Piece Full Port Ball Valve

Female NPT Thread, 82-100 & 82-140: 600 CWP (psig), 150 SWP (psig). 82A-140: 400 CWP (psig), 150 SWP (psig).
 Vacuum Service to 29 inches Hg.
 MSS SP-110 compliant.
 CRN: OC10908.5C



FEATURES

- Adjustable packing gland
- Blow-out-proof stem design
- Reinforced seats
- Inline repairable
- Full port ball configuration

VARIATIONS AVAILABLE:

82-100 Series Standard
 82-140 Series 316 SS Ball & Stem
 82A-140 Series 3" & 4" Only (No Options Available)

OPTIONS AVAILABLE: (More information in Section J)

(SUFFIX)	OPTION	SIZES
-01	Standard Configuration	All
-P -01-	BSPP (Parallel) Thread Connection	1/4" to 4"
-T -01-	BSPT (Tapered) Thread Connection	1/4" to 4"
-02-	Static Grounded	1/4" to 4"
-04-	2.25" Stem Extension	1/4" to 2"
-05-	Plain Ball	1/4" to 4"
-07-	Tee Handle	1/4" to 2"
-08-	90° Reversed Stem	1/4" to 4"
-10-	SS Lever & Nut	1/4" to 4"
-11-	Therma-Seal™ Insulating Tee Handle	1/4" to 2"
-14-	Vented Ball	1/4" to 4"
-15-	Round Handle	1/4" to 2"
-16-	Vertical Chain Lever	1/2" to 2"
-18-	Plain Yellow Grip	1/4" to 2"
-19-	Lock plate	1/4" to 2"
-20-	Slot Vented Ball	1/4" to 4"
-21-	UHMWPE Seats	1/4" to 4"
-23-	Tank Flange (2" only)	2" ONLY
-24-	Graphite Stem Packing	1/4" to 4"
-27-	Latch Lock Lever	1/2" to 2.5"
-30-	CamLock Handle	1/4" to 1.25"
-32-	SS Tee Handle & Nut	1/4" to 2"
-35-	PTFE Trim	1/4" to 4"
-39-	SS Hi-Rise Locking Wheel Handle, SS Nut	1/4" to 1.25"
-40-	Cyl-Loc & Grounded	1/4" to 1/2"
-45-	Less Lever & Nut	1/4" to 4"
-46-	Latch-Lock Lever - Lock in Closed Position Only	1/2" to 2"
-47-	SS Oval Latch-Lock Handle & Nut	1/4" to 3/4"
-48-	SS Oval Handle (No Latch) & Nut	1/4" to 2"
-49-	Assembled Dry	1/4" to 4"
-50-	2.25" CS Locking Stem Extension	1/4" to 2"
-56-	Multifill Seats	1/4" - 4"
-57-	Oxygen Cleaned	1/4" to 4"
-58-	Chain Lever - Horizontal	1/2" to 2"
-59-	SS External Trim	1/4" to 4"
-60-	Grounded Ball & Stem	1/4" to 4"
-63-	NPT x Solder	3/8" to 4"
-92-	Balancing Stop	1/4" to 2"

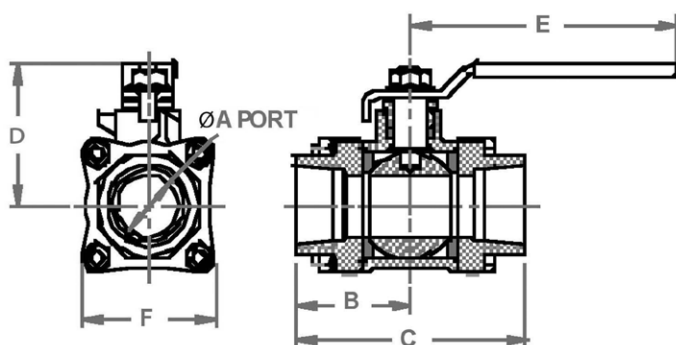

STANDARD MATERIAL LIST

PART	MATERIAL	
1	Lever and grip	Steel, zinc plated w/vinyl
2	Stem packing	MPTFE (Chevron style PTFE 82A 3" & 4")
3	Stem bearing	RPTFE
4	Ball	ASTM B16 (Brass), chrome plated (1/4"-2.5") ASTM 276-316 SS (3"-4")
5	Seat (2)	RPTFE
6	End cap (2)	B16 (1/4" to 3/8"), B584-C84400 (1/2"-4")
7	Gland nut	B16 (Brass)
8	Stem	ASTM B16 (Brass), ASTM 276-316 SS (1/2"-4")
9	Lever nut	Steel, zinc plated
10	Body bolt	Steel, zinc plated
11	Hex nut	Steel, zinc plated
12	Body	ASTM B584-C84400 (Bronze)

PRODUCT NUMBER	SIZE	A	B	C	D	E	F	WT.
82-101-01	1/4"	0.43	1.28	2.56	1.81	3.87	1.60	1.02
82-102-01	3/8"	0.50	1.28	2.56	1.81	3.87	1.60	1.04
82-103-01	1/2"	0.62	1.40	2.81	1.93	4.87	1.78	1.55
82-104-01	3/4"	0.81	1.71	3.43	2.18	4.87	1.98	2.27
82-105-01	1"	1.00	1.93	3.87	2.62	5.50	2.22	3.28
82-106-01	1.25"	1.25	2.37	4.75	2.87	5.50	2.70	5.62
82-107-01	1.5"	1.50	2.62	5.25	3.37	8.00	3.03	8.07
82-108-01	2"	2.00	3.01	6.03	3.68	8.00	3.87	14.42
82-109-01	2.5"	2.50	3.62	7.25	5.14	9.75	5.05	26.61
82A-140-01	3"	3.00	4.18	8.37	8.10	19.13	5.82	43.00
82A-14A-01	4"	4.00	5.43	10.86	8.88	19.13	7.77	106.00

FOR PRESSURE/TEMPERATURE RATINGS,
 REFER TO PAGE M-10, GRAPH NO. 4



FLOW DATA

For Apollo® Ball Valves

The listed Cv "factors" are derived from actual flow testing, in the Apollo® Ball Valve Division, Conbraco Industries, Inc., Pageland, South Carolina. These tests were completed using standard "off the shelf" valves with no special preparation and utilizing standard schedule 40 pipe. It should be understood that these factors are for the valve only and also include the connection configuration. The flow testing is done utilizing water as a fluid media and is a direct statement of the gallons of water flowed per minute with a 1 psig pressure differential across the valve/connection unit. Line pressure is not a factor. Because the Cv is a factor, the formula can be used to estimate flow of most media for valve sizing.

FLOW OF LIQUID

$$Q = C_v \sqrt{\frac{\Delta P}{\text{SpGr}}}$$

$$\text{or } \Delta P = \frac{(Q)^2 (\text{SpGr})}{(C_v)^2}$$

Where:

Q = flow in US gpm
 ΔP = pressure drop (psig)
 SpGr = specific gravity at flowing temperature
 Cv = valve constant

FLOW OF GAS

$$Q = 1360 C_v \sqrt{\frac{(\Delta P) (P_2)}{(\text{SpGr}) (T)}}$$

$$\text{or } \Delta P = \frac{5.4 \times 10^{-7} (\text{SpGr}) (T) (Q)^2}{(C_v)^2 (P_2)}$$

Where:

Q = flow in SCFH
 ΔP = pressure drop (psig)
 SpGr = specific gravity (based on air = 1.0)
 P₂ = outlet pressure-psia (psig + 14.7)
 T = (temp. °F + 460)
 Cv = valve constant

Cv FACTORS FOR APOLLO VALVES

SIZE (IN.)	1/4	3/8	1/2	3/4	1	1.25	1.5	2	2.5	3	4	6	8	10	12
VALVE															
32-100/200 Series	5.1	6.6	8	24	30	45	55	95	--	--	--	--	--	--	--
64-100/200 Series	6	7	19	34	50	104	268	309	629	1018	1622	--	--	--	--
64W Series	--	--	--	--	--	--	--	--	629	1018	1622	--	--	--	--
70B-140 Series	8.4	7.2	15	30	43	48	84	108	190	370	670	--	--	--	--
70-100/200 Series	8.4	7.2	15	30	43	48	84	108	190	370	670	--	--	--	--
70-300/400 Series	--	--	15	30	43	48	84	108	--	--	--	--	--	--	--
70-600 Series	2.3	4.5	5.4	12	14	21	34	47	--	--	--	--	--	--	--
70-800 Series	8.4	7.2	15	30	43	48	84	--	--	--	--	--	--	--	--
71AR Series	--	--	--	30	43	48	84	108	190	370	--	--	--	--	--
71-100/200 Series	--	--	--	30	43	48	84	108	190	370	--	--	--	--	--
72-100/900 Series	--	--	26	48	65	125	170	216	--	--	--	--	--	--	--
73A-100 Series	8.4	7.2	15	30	43	48	84	108	--	--	--	--	--	--	--
73-300/400 Series	--	--	26	48	65	125	170	216	--	--	--	--	--	--	--
74-100 Series	8.4	7.2	15	30	43	48	84	108	190	370	670	--	--	--	--
75-100 Series	8.4	7.2	15	30	43	48	84	108	190	370	670	--	--	--	--
76AR Series	8.4	7.2	15	30	43	48	84	108	190	370	670	--	--	--	--
76F-100 Series	8.1	15	15	51	68	125	177	389	--	--	--	--	--	--	--
76-100 Series	8.4	7.2	15	30	43	48	84	108	190	370	--	--	--	--	--
76-300/400 Series	--	--	26	48	65	125	170	216	--	--	--	--	--	--	--
76-600 Series	2.3	4.5	5.4	12	14	21	34	47	--	--	--	--	--	--	--
7K-100 Series	--	--	15	51	68	125	177	389	503	--	--	--	--	--	--
77AR Series	8.1	15	15	51	68	125	177	389	--	--	--	--	--	--	--
77C-100/200 Series	4.5	7.2	16	36	68	125	177	389	503	--	--	--	--	--	--
77D-140 Series	4.5	7.2	16	36	68	125	177	389	--	--	--	--	--	--	--
77D-640 Series	--	--	--	11	24	35	--	--	--	--	--	--	--	--	--
77G-UL Series	4.5	7.2	16	36	68	125	177	389	503	--	--	--	--	--	--
77W Series	--	--	16	36	68	125	177	389	--	--	--	--	--	--	--
77X Series	--	--	16	36	68	--	--	--	--	--	--	--	--	--	--
77-100/200 Series	8.1	15	15	51	68	125	177	389	503	--	--	--	--	--	--
79 Series	8.5	8.5	9.8	32	44	66	148	218	440	390	--	--	--	--	--

continued on next page



FLOW DATA

For Apollo® Ball Valves

Cv FACTORS FOR APOLLO VALVES (continued from page M-3)

SIZE (IN.)	1/4	3/8	1/2	3/4	1	1.25	1.5	2	2.5	3	4	6	8	10	12
VALVE															
80/81 Series	8.4	7.2	15	30	43	48	84	108	190	370	--	--	--	--	--
82-100/200 Series	8.1	14	26	51	68	120	170	376	510	996	1893	--	--	--	--
83A/83B Series	8.1	14	26	51	68	120	170	376	--	--	--	--	--	--	--
83R-100/200 Series	--	--	--	--	--	--	170	376	--	996	1893	--	--	--	--
86A/86B Series	8.1	14	26	51	68	120	170	376	--	--	--	--	--	--	--
86R-100/200 Series	--	--	--	--	--	--	170	376	--	996	1893	--	--	--	--
87A-100 Series	--	--	--	--	--	--	86	104	234	375	673	1099	1902	3890	--
87A-200 Series	--	--	15	19	75	--	195	410	545	1021	2016	4837	9250	15170	22390
87A-700 Series	--	--	--	--	--	--	86	104	234	375	673	1099	1902	3890	--
87A-900 Series	--	--	15	19	75	--	195	410	545	1021	2016	4837	9250	15170	22390
87B-100 Series	--	--	--	--	--	--	--	--	--	375	673	1099	1902	3890	--
88A-100 Series	--	--	--	--	--	--	86	104	234	375	673	1099	1902	3890	--
88A-200 Series	--	--	15	19	75	--	195	410	545	1021	2016	4837	9250	15170	22390
88A-700 Series	--	--	--	--	--	--	86	104	234	375	673	1099	1902	3890	--
88A-900 Series	--	--	15	19	75	--	195	410	545	1021	2016	4837	9250	15170	22390
88B-100 Series	--	--	--	--	--	--	--	--	--	375	673	1099	1902	3890	--
89-100 Series	8.4	7.2	15	30	43	48	84	108	190	370	--	--	--	--	--
9A-100 Series	8.3	6.7	5.7	10	16	25	40	62	--	--	--	--	--	--	--
91-100 Series	8.3	6.7	5.7	10	16	25	40	62	--	--	--	--	--	--	--
92-100 Series	8.3	6.7	5.7	10	16	25	40	62	--	--	--	--	--	--	--
93-100 Series	8.3	6.7	5.7	10	16	25	40	62	--	--	--	--	--	--	--
94A-100/200 Series	6	7	19	34	50	104	268	309	629	1018	1622	--	--	--	--
95-100/200 Series	--	--	15	51	68	--	--	--	--	--	--	--	--	--	--
95A-300/400 Series	--	--	19	34	50	--	--	--	--	--	--	--	--	--	--
96-100 Series	8.3	6.7	5.7	10	16	25	40	62	--	--	--	--	--	--	--
399-100 Series	8.4	7.2	15	30	43	48	84	108	190	370	--	--	--	--	--
489-100 Series	8.4	7.2	15	30	43	48	84	108	190	370	--	--	--	--	--

PRESSURE TEMPERATURE RATINGS

400# Bronze (GRAPH 3)

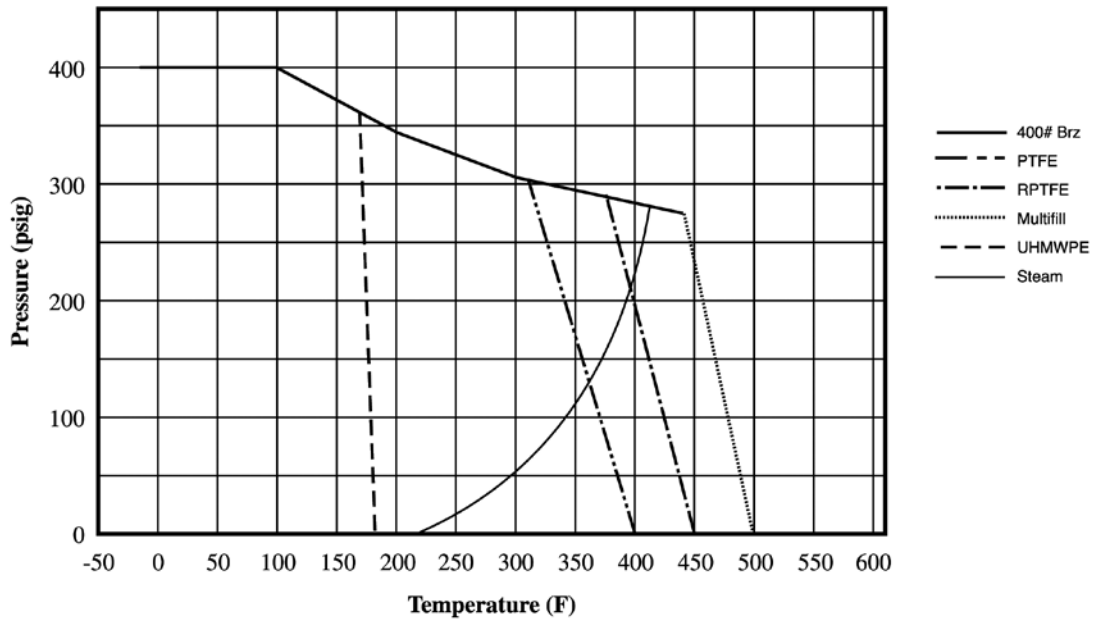

600# Bronze (GRAPH 4)

