

# 76-100 SERIES

## Stainless Steel Ball Valve with Mounting Pad 1/4" - 1"

Female NPT Thread, 2000 CWP (psig). Cold Non-Shock. (See referenced P/T chart)  
 150 psig Saturated Steam.  
 Vacuum Service to 29 inches Hg.  
 MSS SP-110 compliant.



### FEATURES

- Investment cast components
- Reinforced seats
- Mounting pad for easy actuator mounting
- Blow-out-proof stem design
- Adjustable packing gland
- Stainless Steel lever and nut

- Fire tested API 607, 6th edition (Requires "24" suffix)
- Meets NACE MR0175 (2000) & MR0103 (2012)
- CSA/CAN 3.16-M88 (2009) (Requires "01" suffix)
- NSF/ANSI 61 (2010) Section 8, Annex F & G
- NSF-372, Drinking Water System Components - Lead Content

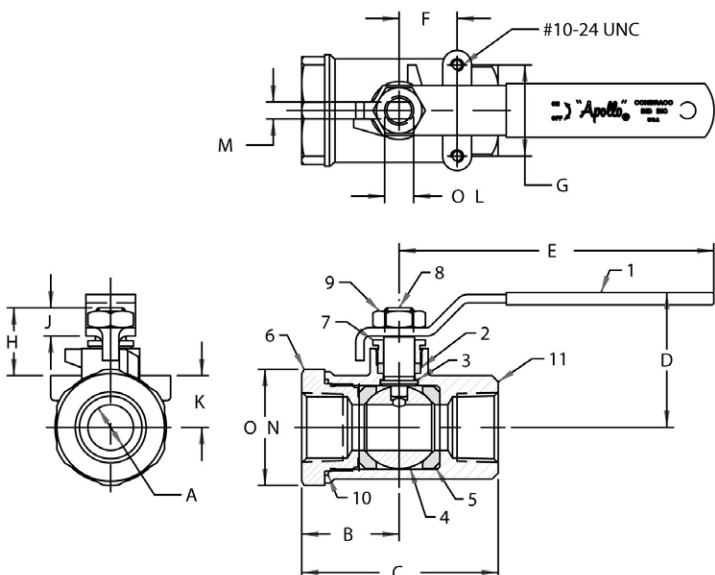

### OPTIONS AVAILABLE: (More information in Section J)

(SUFFIX)	OPTION	SIZES
-01	Standard Configuration	All
-P -01-	BSPP (Parallel) Thread Connection	1/4" to 3"
-T -01-	BSPT (Tapered) Thread Connection	1/4" to 3"
-02-	Stem Grounded	1/4" to 3"
-04-	2.25" CS Stem Extension	1/4" to 3"
-07-	Steel Tee Handle	1/4" to 2"
-08-	90° Reversed Stem	1/4" to 3"
-14-	Side Vented Ball (Uni-Directional)	1/4" to 2"
-15-	Wheel Handle, Steel	1/4" to 2"
-16-	Chain Lever - Vertical	3/4" to 2"
-19-	Lock Plate	1/4" to 2"
-21-	UHMWPE Trim (Non-PTFE)	1/4" to 3"
-24-	Graphite Packing	1/4" to 3"
-27-	SS Latch-Lock Lever & Nut	1/4" to 3"
-30-	Cam-Lock and Grounded	1/4" to 2"
-32-	SS Tee Handle & Nut	1/4" to 2"
-35-	PTFE Trim	1/4" to 3"
-39-	SS Hi-Rise Locking Wheel Handle, SS Nut	1/4" to 2"
-40-	Cyl-Loc and Grounded	1/4" to 2"
-44-	Seal Welded	1/4" to 2"
-45-	Less Lever & Nut	1/4" to 3"
-46-	Latch Lock Lever - Lock in Closed Position Only	1/4" to 3"
-47-	SS Latch Lock Oval Handle	1/4" to 2"
-48-	SS Oval Handle (No Latch) & Nut	1/4" to 2"
-49-	No Lubrication. Assembled Dry.	1/4" to 3"
-50-	2.25" CS Locking Stem Extension	1/4" to 3"
-57-	Oxygen Cleaned	1/4" to 3"
-58-	Chain Lever - Horizontal	3/4" to 2"
-60-	Static Grounded Ball & Stem	1/4" to 3"
-64-	250# Steam Trim	1/4" to 3"

### STANDARD MATERIAL LIST

PART	MATERIAL	
1	Lever and grip	304 SS w/vinyl
2	Stem packing	MPTFE
3	Stem bearing	RPTFE
4	Ball	A276-316 Stainless Steel
5	Seat (2)	RPTFE
6	Retainer	A351-CF8M Stainless Steel
7	Gland nut	A276-316 Stainless Steel
8	Stem	A276-316 Stainless Steel
9	Lever nut	18-8 Stainless Steel
10	Body seal	PTFE
11	Body	A351-CF8M Stainless Steel

PRODUCT NUMBER	SIZE	A	B	C	D	E	F	G	H	J	K	L	M	N	WT.
76-101-01A	1/4"	0.37	1.02	2.05	1.71	3.85	0.50	1.12	0.88	0.34	0.53	0.375	0.234	1.16	0.58
76-102-01A	3/8"	0.37	1.02	2.05	1.71	3.85	0.50	1.12	0.88	0.34	0.53	0.375	0.234	1.16	0.55
76-103-01A	1/2"	0.50	1.12	2.23	1.79	3.85	0.50	1.12	0.90	0.34	0.59	0.375	0.234	1.38	0.63
76-104-01A	3/4"	0.68	1.47	2.96	2.03	4.75	0.87	1.37	1.02	0.42	0.78	0.437	0.256	1.75	1.30
76-105-01A	1"	0.87	1.67	3.34	2.16	4.75	0.87	1.37	1.02	0.42	0.91	0.437	0.256	1.94	1.60

FOR PRESSURE/TEMPERATURE RATINGS, REFER TO PAGE M-14, GRAPH NO. 14

# 76-100 SERIES

## Stainless Steel Ball Valve with Mounting Pad 1.25" - 2"

Female NPT Thread, 1500 CWP (psig). Cold Non-Shock. (See referenced P/T chart)  
 150 psig Saturated Steam.  
 Vacuum Service to 29 inches Hg.  
 MSS SP-110 compliant.



### FEATURES

- Investment cast components
- Reinforced seats
- Mounting pad for easy actuator mounting
- Blow-out-proof stem design
- Adjustable packing gland
- Stainless Steel lever and nut

- Fire tested API 607, 6th edition (Requires "24" suffix)
- Meets NACE MR0175 (2000) & MR0103 (2012)
- CSA/CAN 3.16-M88 (2009) (Requires "01" suffix)
- NSF/ANSI 61 (2010) Section 8, Annex F & G
- NSF-372, Drinking Water System Components - Lead Content

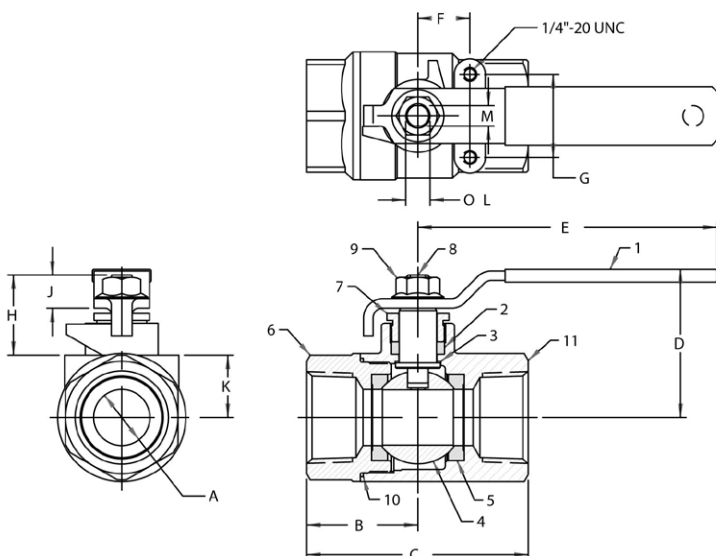

### OPTIONS AVAILABLE: (More information in Section J)

(SUFFIX)	OPTION	SIZES
-01	Standard Configuration	All
-P -01-	BSPP (Parallel) Thread Connection	1/4" to 3"
-T -01-	BSPT (Tapered) Thread Connection	1/4" to 3"
-02-	Stem Grounded	1/4" to 3"
-04-	2.25" CS Stem Extension	1/4" to 3"
-07-	Steel Tee Handle	1/4" to 2"
-08-	90° Reversed Stem	1/4" to 3"
-14-	Side Vented Ball (Uni-Directional)	1/4" to 2"
-15-	Wheel Handle, Steel	1/4" to 2"
-16-	Chain Lever - Vertical	3/4" to 2"
-19-	Lock Plate	1/4" to 2"
-21-	UHMWPE Trim (Non-PTFE)	1/4" to 3"
-24-	Graphite Packing	1/4" to 3"
-27-	SS Latch-Lock Lever & Nut	1/4" to 3"
-30-	Cam-Lock and Grounded	1/4" to 2"
-32-	SS Tee Handle & Nut	1/4" to 2"
-35-	PTFE Trim	1/4" to 3"
-39-	SS Hi-Rise Locking Wheel Handle, SS Nut	1/4" to 2"
-40-	Cyl-Loc and Grounded	1/4" to 2"
-44-	Seal Welded	1/4" to 2"
-45-	Less Lever & Nut	1/4" to 3"
-46-	Latch Lock Lever - Lock in Closed Position Only	1/4" to 3"
-47-	SS Latch Lock Oval Handle	1/4" to 2"
-48-	SS Oval Handle (No Latch) & Nut	1/4" to 2"
-49-	No Lubrication. Assembled Dry.	1/4" to 3"
-50-	2.25" CS Locking Stem Extension	1/4" to 3"
-57-	Oxygen Cleaned	1/4" to 3"
-58-	Chain Lever - Horizontal	3/4" to 2"
-60-	Static Grounded Ball & Stem	1/4" to 3"
-64-	250# Steam Trim	1/4" to 3"

### STANDARD MATERIAL LIST

PART	MATERIAL	
1	Lever and grip	304 SS w/vinyl
2	Stem packing	MPTFE
3	Stem bearing	RPTFE
4	Ball	A276-316 Stainless Steel
5	Seat (2)	RPTFE
6	Retainer	A351-CF8M Stainless Steel
7	Gland nut	A276-316 Stainless Steel
8	Stem	A276-316 Stainless Steel
9	Lever nut	18-8 Stainless Steel
10	Body seal	PTFE
11	Body	A351-CF8M Stainless Steel

PRODUCT NUMBER	SIZE	A	B	C	D	E	F	G	H	J	K	L	M	WT.
76-106-01	1.25"	1.00	2.00	4.00	2.68	5.40	0.94	1.50	1.50	0.60	1.12	0.625	0.377	3.10
76-107-01	1.5"	1.25	2.17	4.34	3.25	7.75	0.94	1.50	1.50	0.60	1.28	0.625	0.377	4.20
76-108-01	2"	1.50	2.69	5.43	3.24	7.75	0.94	1.50	1.46	0.60	1.50	0.625	0.377	6.10

FOR PRESSURE/TEMPERATURE RATINGS, REFER TO PAGE M-13, GRAPH NO. 12



# 76-100 SERIES

## Stainless Steel Ball Valve 2.5" - 3"

Female NPT Thread, 1000 CWP (psig). Cold Non-Shock. (See referenced P/T chart)  
 150 psig Saturated Steam.  
 Vacuum Service to 29 inches Hg.  
 MSS SP-110 compliant.



### FEATURES

- Investment cast components
- Reinforced seats
- Mounting pad for easy actuator mounting
- Blow-out-proof stem design
- Adjustable packing gland
- Adjustable packing gland
- Stainless Steel lever and nut

- Fire tested API 607, 6th edition (Requires "24" suffix)
- Meets NACE MR0175 (2000) & MR0103 (2012)
- CSA/CAN 3.16-M88 (2009) (Requires "01" suffix)
- NSF/ANSI 61 (2010) Section 8, Annex F & G
- NSF-372, Drinking Water System Components - Lead Content

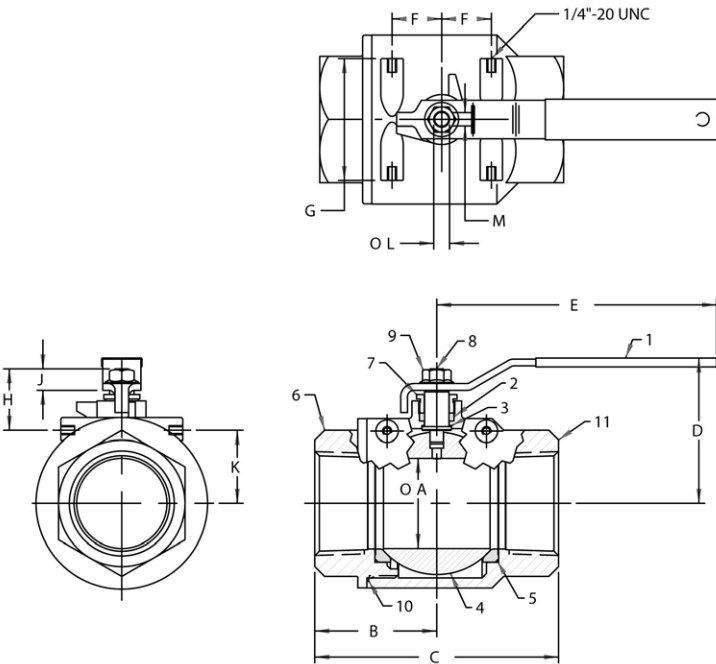

### OPTIONS AVAILABLE: (More information in Section J)

(SUFFIX)	OPTION	SIZES
-01	Standard Configuration	All
-02-	Stem Grounded	1/4" to 3"
-04-	2.25" CS Stem Extension	1/4" to 3"
-07-	Steel Tee Handle	1/4" to 2"
-08-	90° Reversed Stem	1/4" to 3"
-14-	Side Vented Ball (Uni-Directional)	1/4" to 2"
-15-	Wheel Handle, Steel	1/4" to 2"
-16-	Chain Lever - Vertical	3/4" to 2"
-19-	Lock Plate	1/4" to 2"
-21-	UHMWPE Trim (Non-PTFE)	1/4" to 3"
-24-	Graphite Packing	1/4" to 3"
-27-	SS Latch-Lock Lever & Nut	1/4" to 3"
-30-	Cam-Lock and Grounded	1/4" to 2"
-32-	SS Tee Handle & Nut	1/4" to 2"
-35-	PTFE Trim	1/4" to 3"
-39-	SS Hi-Rise Locking Wheel Handle, SS Nut	1/4" to 2"
-40-	Cyl-Loc and Grounded	1/4" to 2"
-44-	Seal Welded	1/4" to 2"
-45-	Less Lever & Nut	1/4" to 3"
-46-	Latch Lock Lever - Lock in Closed Position Only	1/4" to 3"
-47-	SS Latch Lock Oval Handle	1/4" to 2"
-48-	SS Oval Handle (No Latch) & Nut	1/4" to 2"
-49-	No Lubrication. Assembled Dry.	1/4" to 3"
-50-	2.25" CS Locking Stem Extension	1/4" to 3"
-57-	Oxygen Cleaned	1/4" to 3"
-58-	Chain Lever - Horizontal	3/4" to 2"
-60-	Static Grounded Ball & Stem	1/4" to 3"
-64-	250# Steam Trim	1/4" to 3"

### STANDARD MATERIAL LIST

PART	MATERIAL	
1	Lever and grip	304 SS w/vinyl
2	Stem packing	MPTFE
3	Stem bearing	RPTFE
4	Ball	A276-316 Stainless Steel
5	Seat (2)	RPTFE
6	Retainer	A351-CF8M Stainless Steel
7	Gland nut	A276-316 Stainless Steel
8	Stem	A276-316 Stainless Steel
9	Lever nut	18-8 Stainless Steel
10	Body seal	PTFE
11	Body	A351-CF8M Stainless Steel

**FOR PRESSURE/TEMPERATURE RATINGS, REFER TO PAGE M-12, GRAPH NO. 8**

PRODUCT NUMBER	SIZE	A	B	C	D	E	F	G	H	J	K	L	M	WT.
76-109-01	2.5"	2.50	3.38	6.75	4.03	7.75	1.38	3.37	1.71	0.60	2.00	0.625	0.377	15.60
76-100-01	3"	2.50	3.38	6.75	4.03	7.75	1.38	3.37	1.71	0.60	2.00	0.625	0.377	16.50

# FLOW DATA

## For Apollo® Ball Valves

The listed Cv "factors" are derived from actual flow testing, in the Apollo® Ball Valve Division, Conbraco Industries, Inc., Pageland, South Carolina. These tests were completed using standard "off the shelf" valves with no special preparation and utilizing standard schedule 40 pipe. It should be understood that these factors are for the valve only and also include the connection configuration. The flow testing is done utilizing water as a fluid media and is a direct statement of the gallons of water flowed per minute with a 1 psig pressure differential across the valve/connection unit. Line pressure is not a factor. Because the Cv is a factor, the formula can be used to estimate flow of most media for valve sizing.

### FLOW OF LIQUID

$$Q = C_v \sqrt{\frac{\Delta P}{SpGr}}$$

$$\text{or } \Delta P = \frac{(Q)^2 (SpGr)}{(C_v)^2}$$

**Where:**

Q = flow in US gpm  
 ΔP = pressure drop (psig)  
 SpGr = specific gravity at flowing temperature  
 Cv = valve constant

### FLOW OF GAS

$$Q = 1360 C_v \sqrt{\frac{(\Delta P) (P_2)}{(SpGr) (T)}}$$

$$\text{or } \Delta P = \frac{5.4 \times 10^{-7} (SpGr) (T) (Q)^2}{(C_v)^2 (P_2)}$$

**Where:**

Q = flow in SCFH  
 ΔP = pressure drop (psig)  
 SpGr = specific gravity (based on air = 1.0)  
 P<sub>2</sub> = outlet pressure-psia (psig + 14.7)  
 T = (temp. °F + 460)  
 Cv = valve constant

### Cv FACTORS FOR APOLLO VALVES

SIZE (IN.)	1/4	3/8	1/2	3/4	1	1.25	1.5	2	2.5	3	4	6	8	10	12
<b>VALVE</b>															
32-100/200 Series	5.1	6.6	8	24	30	45	55	95	--	--	--	--	--	--	--
64-100/200 Series	6	7	19	34	50	104	268	309	629	1018	1622	--	--	--	--
64W Series	--	--	--	--	--	--	--	--	629	1018	1622	--	--	--	--
70B-140 Series	8.4	7.2	15	30	43	48	84	108	190	370	670	--	--	--	--
70-100/200 Series	8.4	7.2	15	30	43	48	84	108	190	370	670	--	--	--	--
70-300/400 Series	--	--	15	30	43	48	84	108	--	--	--	--	--	--	--
70-600 Series	2.3	4.5	5.4	12	14	21	34	47	--	--	--	--	--	--	--
70-800 Series	8.4	7.2	15	30	43	48	84	--	--	--	--	--	--	--	--
71AR Series	--	--	--	30	43	48	84	108	190	370	--	--	--	--	--
71-100/200 Series	--	--	--	30	43	48	84	108	190	370	--	--	--	--	--
72-100/900 Series	--	--	26	48	65	125	170	216	--	--	--	--	--	--	--
73A-100 Series	8.4	7.2	15	30	43	48	84	108	--	--	--	--	--	--	--
73-300/400 Series	--	--	26	48	65	125	170	216	--	--	--	--	--	--	--
74-100 Series	8.4	7.2	15	30	43	48	84	108	190	370	670	--	--	--	--
75-100 Series	8.4	7.2	15	30	43	48	84	108	190	370	670	--	--	--	--
76AR Series	8.4	7.2	15	30	43	48	84	108	190	370	670	--	--	--	--
76F-100 Series	8.1	15	15	51	68	125	177	389	--	--	--	--	--	--	--
76-100 Series	8.4	7.2	15	30	43	48	84	108	190	370	--	--	--	--	--
76-300/400 Series	--	--	26	48	65	125	170	216	--	--	--	--	--	--	--
76-600 Series	2.3	4.5	5.4	12	14	21	34	47	--	--	--	--	--	--	--
7K-100 Series	--	--	15	51	68	125	177	389	503	--	--	--	--	--	--
77AR Series	8.1	15	15	51	68	125	177	389	--	--	--	--	--	--	--
77C-100/200 Series	4.5	7.2	16	36	68	125	177	389	503	--	--	--	--	--	--
77D-140 Series	4.5	7.2	16	36	68	125	177	389	--	--	--	--	--	--	--
77D-640 Series	--	--	--	11	24	35	--	--	--	--	--	--	--	--	--
77G-UL Series	4.5	7.2	16	36	68	125	177	389	503	--	--	--	--	--	--
77W Series	--	--	16	36	68	125	177	389	--	--	--	--	--	--	--
77X Series	--	--	16	36	68	--	--	--	--	--	--	--	--	--	--
77-100/200 Series	8.1	15	15	51	68	125	177	389	503	--	--	--	--	--	--
79 Series	8.5	8.5	9.8	32	44	66	148	218	440	390	--	--	--	--	--

continued on next page



# FLOW DATA

## For Apollo® Ball Valves

### Cv FACTORS FOR APOLLO VALVES (continued from page M-3)

SIZE (IN.)	1/4	3/8	1/2	3/4	1	1.25	1.5	2	2.5	3	4	6	8	10	12
<b>VALVE</b>															
80/81 Series	8.4	7.2	15	30	43	48	84	108	190	370	--	--	--	--	--
82-100/200 Series	8.1	14	26	51	68	120	170	376	510	996	1893	--	--	--	--
83A/83B Series	8.1	14	26	51	68	120	170	376	--	--	--	--	--	--	--
83R-100/200 Series	--	--	--	--	--	--	170	376	--	996	1893	--	--	--	--
86A/86B Series	8.1	14	26	51	68	120	170	376	--	--	--	--	--	--	--
86R-100/200 Series	--	--	--	--	--	--	170	376	--	996	1893	--	--	--	--
87A-100 Series	--	--	--	--	--	--	86	104	234	375	673	1099	1902	3890	--
87A-200 Series	--	--	15	19	75	--	195	410	545	1021	2016	4837	9250	15170	22390
87A-700 Series	--	--	--	--	--	--	86	104	234	375	673	1099	1902	3890	--
87A-900 Series	--	--	15	19	75	--	195	410	545	1021	2016	4837	9250	15170	22390
87B-100 Series	--	--	--	--	--	--	--	--	--	375	673	1099	1902	3890	--
88A-100 Series	--	--	--	--	--	--	86	104	234	375	673	1099	1902	3890	--
88A-200 Series	--	--	15	19	75	--	195	410	545	1021	2016	4837	9250	15170	22390
88A-700 Series	--	--	--	--	--	--	86	104	234	375	673	1099	1902	3890	--
88A-900 Series	--	--	15	19	75	--	195	410	545	1021	2016	4837	9250	15170	22390
88B-100 Series	--	--	--	--	--	--	--	--	--	375	673	1099	1902	3890	--
89-100 Series	8.4	7.2	15	30	43	48	84	108	190	370	--	--	--	--	--
9A-100 Series	8.3	6.7	5.7	10	16	25	40	62	--	--	--	--	--	--	--
91-100 Series	8.3	6.7	5.7	10	16	25	40	62	--	--	--	--	--	--	--
92-100 Series	8.3	6.7	5.7	10	16	25	40	62	--	--	--	--	--	--	--
93-100 Series	8.3	6.7	5.7	10	16	25	40	62	--	--	--	--	--	--	--
94A-100/200 Series	6	7	19	34	50	104	268	309	629	1018	1622	--	--	--	--
95-100/200 Series	--	--	15	51	68	--	--	--	--	--	--	--	--	--	--
95A-300/400 Series	--	--	19	34	50	--	--	--	--	--	--	--	--	--	--
96-100 Series	8.3	6.7	5.7	10	16	25	40	62	--	--	--	--	--	--	--
399-100 Series	8.4	7.2	15	30	43	48	84	108	190	370	--	--	--	--	--
489-100 Series	8.4	7.2	15	30	43	48	84	108	190	370	--	--	--	--	--

# PRESSURE TEMPERATURE RATINGS

## 2000# CS (GRAPH 13)

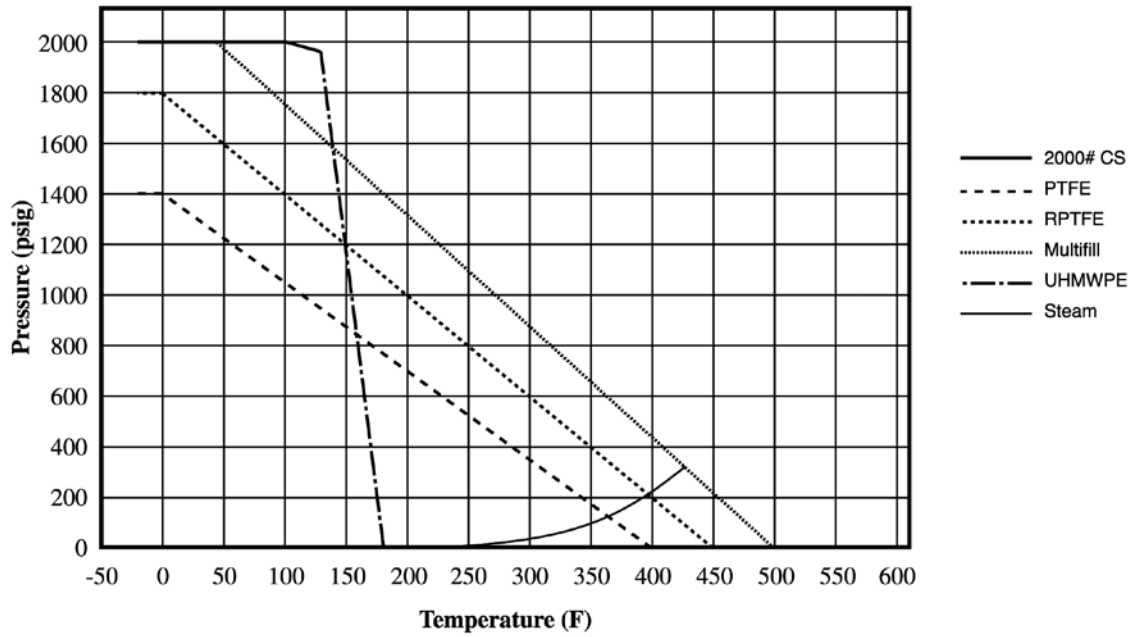

## 2000# SS (GRAPH 14)

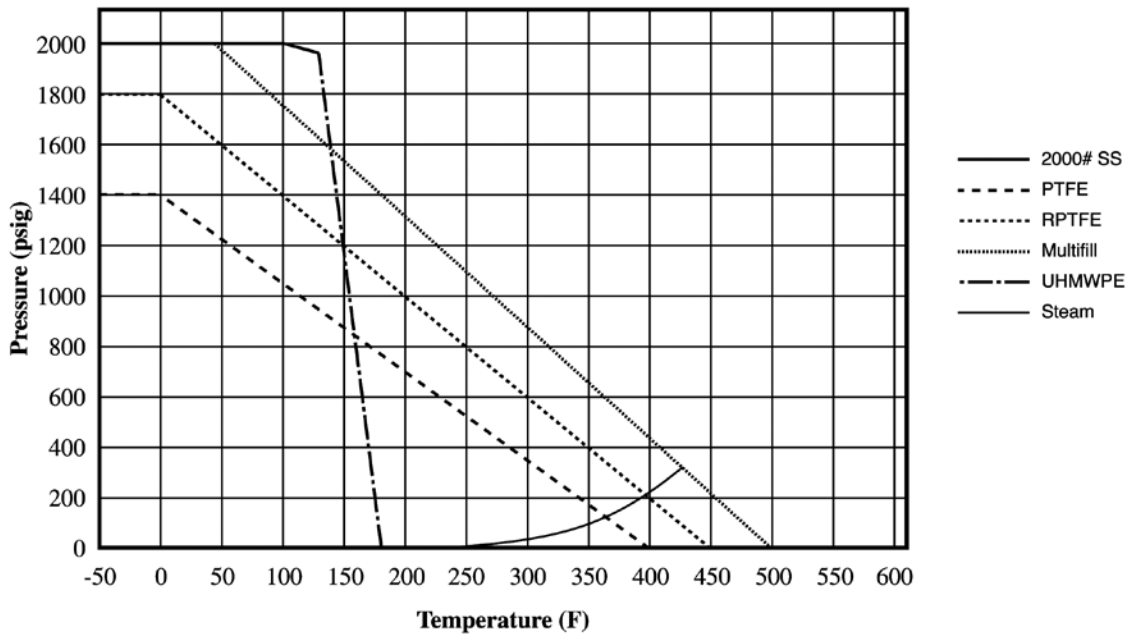

# PRESSURE TEMPERATURE RATINGS

## 1500# CS (GRAPH 11)

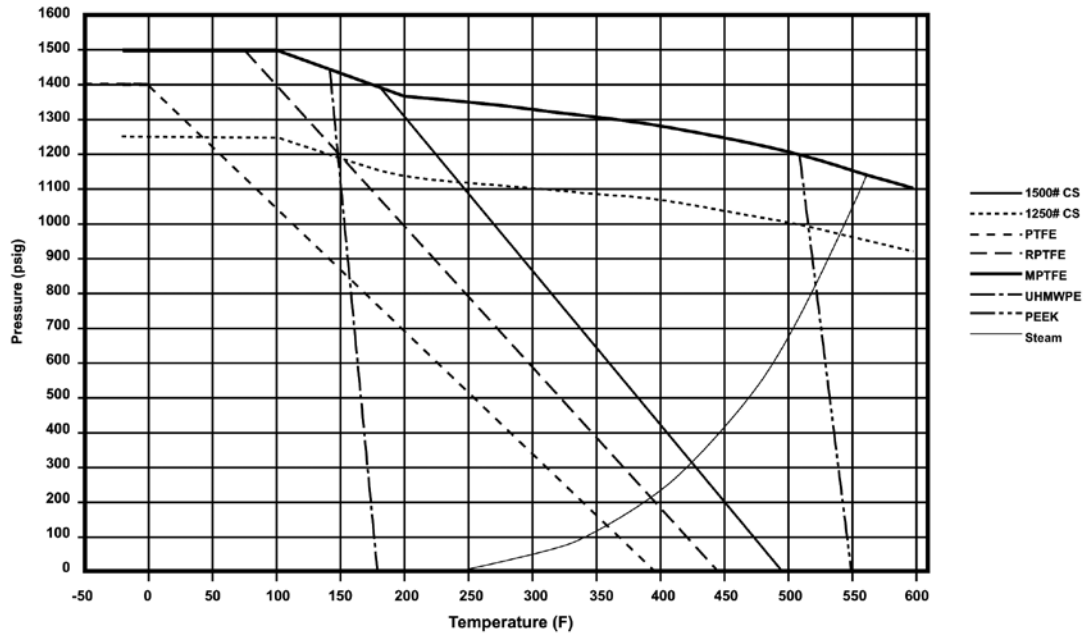

## 1500# SS (GRAPH 12)

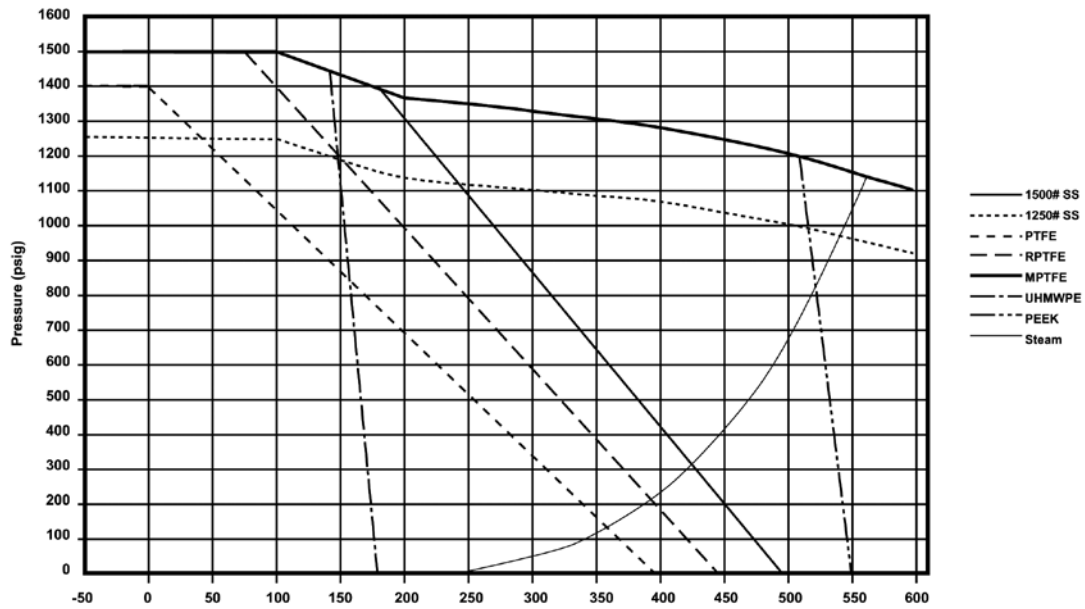

# PRESSURE TEMPERATURE RATINGS

## 1000# CS (GRAPH 7)

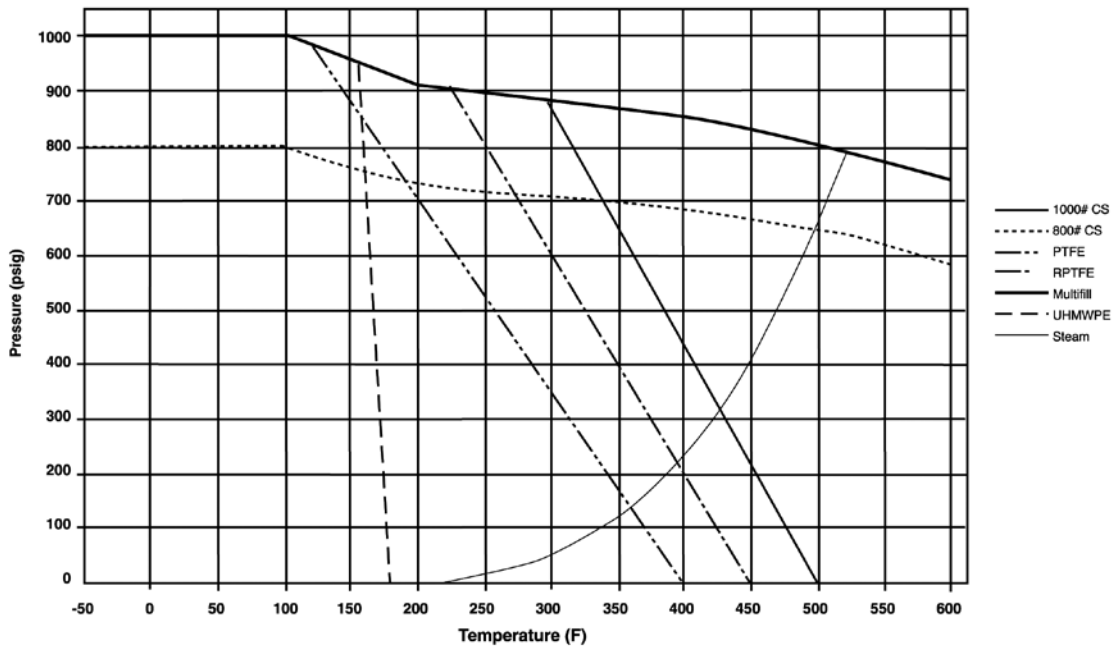

## 1000# SS (GRAPH 8)

