



GroovJoint™



Grooved Stainless Steel Fittings
Submittal documents prepared for



Table of Contents

Section 1: **Company Profile**

Section 2: **About GroovJoint**

Section 3: **Approvals/Certification**

Section 4: **Stainless Steel Grooved Fittings**

Section 5: **Grooved Piping Systems Installation Instructions**



Company Profile

SINCE 2003: A COMMITMENT TO COMPLETE CUSTOMER SATISFACTION

In the ever-changing world of construction management, there are always new and exciting companies that come to market in order to help reduce the contractors costs and improve the time it takes to complete a project safely and under budget.

With that premise in mind. GroovJoint LLC was founded as a company that could deliver a complete combination of value, products, services, and personal performances. Due to a strong commitment to this critical and core belief, this has been our business philosophy since day one.

Headquartered in Chicago, Illinois, is our global sales office. The midwestern United States is home to some of the hardest working people in the United States that we draw our talent from. We also rely on many other manufacturing companies throughout the United States to provide us with quality raw materials and services.

We are a company that has experienced year over year growth during a global construction downturn during the past five-plus years. That in itself is a testament to our business model. As a manufacturing company that competes on a global scale, we must constantly seek ways to produce our product in a manner that is lean, equitable and empowered.

Lean with regard to our manufacturing philosophy.

Equitable in our commitment to balance people and profit.

Empowered by building a work force that is committed to quality.

Our management team has over 100+ years in the piping industry. Because our only product is stainless steel piping components, it allows us to be experts at what we do best. We constantly measure our performance and look for new ways to improve our product through collaboration with our suppliers.

Our company and our employees all believe in a few basic principles;

1. Our primary mission is to serve our customer.
2. We are to provide quality products to the construction industry.
3. All of our products must be priced competitively.
4. Service is what sets us apart from the competition.

These basic principles are the foundation of our company.

Those basic principles are what makes us a company that you can rely on to help complete your construction projects on time.



About GroovJoint

Since 2003, GroovJoint has been providing quality stainless steel piping products in a wide range of applications.

Located in the heart of the Midwestern United States, GroovJoint utilizes skilled craftsmen and quality raw materials to produce exceptional products right here in the USA.

Our innovative design team can customize our offerings to meet your toughest needs.

The GroovJoint product line includes the following products:

GroovJoint Grooved Fittings are produced in Sch. 10 and Sch. 40 pipe thicknesses. The size range for Sch. 10 stainless steel is 1" - 24" roll grooved in both 304L and 316L grades. In Sch. 40 stainless steel, the range is 1" - 12" in both 304L and 316L. The Sch. 40 product line includes both roll grooved and cut grooved ends. The product line also includes stainless steel Flanged Adaptors in Sch. 10 and Sch. 40 material in 304L and 316L grades.

PressJoint press end fittings are offered in a wide range of sizes and configurations (1/2" - 2") compatible with both Sch. 5 and Sch. 10S stainless steel pipe. The PressJoint fitting method allows easier installation than traditional welded or threaded piping methods. It can be used in a wide range of applications.

All of the products listed above are used in the following industries:

- Mining
- Pulp and Paper
- HVAC
- Mechanical
- Plumbing
- Fire Protection
- Process Piping
- Marine
- Oil and Gas

Let GroovJoint handle your piping needs.



Approvals/Certification

GroovJoint fittings undergo rigorous testing before going to market. All fittings must pass dimensional and chemical analysis prior to shipping.



The image features a central orange rectangular area with the text "Stainless Steel Grooved Fittings" in bold black font. This central area is framed by a dark horizontal line above and below it, which in turn is set against a background of a light brown, textured stone wall with visible grooves and irregular shapes.

Stainless Steel Grooved Fittings

GroovJoint Stainless Steel Grooved Fittings Product Line

GroovJoint Stainless Steel Grooved Pipe Fittings are designed to reduce labor costs in the field by using the grooved method for the installation of piping systems.

GroovJoint grooved pipe fittings are full-flow design in both 304L and 316L grades of stainless steel, conforming to ASTM A403 in sizes 1" - 12".

For product ranging from 1" - 12", fittings are offered in both Sch. 10 and Sch. 40 wall thicknesses. Sch. 40 fittings can be roll grooved or cut grooved depending on the customer's requirements.

14" - 24" roll grooved fittings are manufactured from material conforming to:

90° Elbows: A403WPW/A774

45° Elbows: A403WPW/A774

Tees: A403CR

Reducing Tees: A403CR

Concentric Reducers: A403CR

Laterals: A774/ASTM774



Certified to
NSF/ANSI 61



Certified to
NSF/ANSI 61-G



GroovJoint reserves the right to change the contents without notice.

RIGID COUPLING – STAINLESS STEEL

GENERAL DESCRIPTION

The **GroovJoint** Model 24 Stainless Steel Rigid Coupling is an angle-pad design stainless steel coupling for use with Sch. 5S, Sch. 10S or Sch. 40S stainless steel pipe where a rigid connection is desired. The angle-pad design allows the coupling housings to slide along the bolt pads when tightened. The result is an offset clamping action which provides a rigid joint which resists so called 'snaking' of a long straight run. With the removal of only one bolt you can make a fast and easy installation. The Model 24 couplings are comprised of two identical CF8M (316) housing segments, EPDM gaskets and stainless steel track bolts and heavy duty nuts.

Model 24 couplings should always be installed so that the coupling bolt pads make metal to metal contact.

The Model 24 Stainless Steel Rigid Coupling is available with a standard "C" shaped gasket in a variety of grades to meet your specific service requirements.

TECHNICAL DATA

Sizes: Inches / DN: 2" to 12" (DN50 to DN300)

Approvals: UL, ULC, NSF-61

Maximum Pressure: See Figure 1.

Housing: Type 316 Stainless Steel conforming to ASTM A-743/A-743M – Standard specification for castings, iron-chromium, iron-chromium-nickel, corrosion resistant, for general application.

Bolt/Nuts: Stainless Steel bolts are conforming to ASTM A-193M Class 2, Type 304, Grade B8M. Class 2. Stainless Steel nuts are hex nuts conforming to ASTM A-194M Type 304, Grade 8M.

Gasket (specify when ordering):

- Grade "E" EPDM, green color code
-30°F (-34°C) to +230°F (+110°C)
- Grade "T" Nitrile, orange color code
-20°F (-29°C) to +180°F (+82°C)

TERMS & CONDITIONS OF SALE

These terms and conditions shall apply to any purchase order or sales of GroovJoint products.

No alteration, modification or waiver of these terms and conditions whether on Customer's purchase order or otherwise shall be valid unless the alteration, modification or waiver is specifically accepted in writing by an authorized representative of GroovJoint.

Designs and Terms and Conditions of Sale are subject to change without notice.

TERMS OF PAYMENT: As stated on invoice.

MINIMUM INVOICE CHARGES: \$50.00 for any single order.

SHIPPING TERMS: F.O.B. shipping point- freight prepaid and allowed on single orders having a net price value of \$7500 or more, for shipment at one time to one destination, as determined by GroovJoint within the continental United States, excluding Alaska, Hawaii, Puerto Rico and U.S. possessions.

Shipping on orders less than net price value of \$7500, F.O.B. shipping point will be paid by the customer. The cost of any special packaging or handling that has been requested by the customer, and is not part of our normal handling methods, will be added to the order and paid by the customer.

GroovJoint will make every effort to ship by the scheduled delivery date, but reserves the right to ship within a reasonable period thereafter. **GroovJoint shall not be held liable for any kind of damages, including but not limited to incidental or consequential damages for lost revenue or lost sales or liquidated damages, directly or indirectly arising from delays or failure to meet shipping dates.**

Orders, when accepted, cannot be cancelled without our written consent. No material will be taken back without our written consent. **Orders for non-standard (i.e. non-cancellable/non-returnable) material may not be cancelled nor will GroovJoint accept return of such material for credit.**

Claims for corrections must be made within 10 days of receipt of goods. Carriers are responsible for goods lost, damaged or delayed in transit. For your own protection, have Transportation Company's agent verify damages, shortages or delays and note them on freight bill.

WARRANTY

We warrant all products to be free from defects in materials and workmanship under normal conditions of use and service. Our obligation under this warranty is limited to repairing or replacing at our option at our factory any product which shall within one year after delivery to original buyer be returned with transportation charges prepaid, and which our examination shall show to our satisfaction to have been defective.

THIS WARRANTY IS MADE EXPRESSLY IN LIEU OF ANY OTHER WARRANTIES, EXPRESS OR IMPLIED, INCLUDING ANY IMPLIED WARRANTY OF MERCHANTABILITY OR FITNESS FOR A PARTICULAR PURPOSE. THE BUYER'S



SOLE AND EXCLUSIVE REMEDY SHALL BE FOR THE REPAIR OR REPLACEMENT OF DEFECTIVE PRODUCTS AS PROVIDED HEREIN. THE BUYER AGREES THAT NO OTHER REMEDY (INCLUDING, BUT NOT LIMITED TO, INCIDENTAL OR CONSEQUENTIAL DAMAGES FOR LOST PROFITS, LOST SALES, INJURY TO PERSON OR PROPERTY OR ANY OTHER INCIDENTAL OR CONSEQUENTIAL LOSS) SHALL BE AVAILABLE TO HIM.

GroovJoint neither assumes nor authorizes any person to assume for it any other liability in connection with the sale of such products.

PERFORMANCE DATA

The following table shows maximum cold working pressures (CWP) of **GroovJoint** stainless steel couplings used on stainless steel pipe.

In general it is more difficult to achieve defined groove corners on stainless steel pipe than on carbon steel pipe. Always select the correct roll set for the pipe being grooved and process grooves as defined as possible. Contact your roll-groove tool manufacturer for recommendations.

Nom.Size (in / mm)	Roll-Grooved		
	Sch. 40S PSI / Bar	Sch. 10S PSI / Bar	Sch. 5S PSI / Bar
2	600 / 41.1	300 / 20.7	200 / 13.8
2-1/2	600 / 41.1	300 / 20.7	200 / 13.8
3	600 / 41.1	300 / 20.7	200 / 13.8
4	600 / 41.1	300 / 20.7	200 / 13.8
5	600 / 41.1	300 / 20.7	200 / 13.8
6	600 / 41.1	300 / 20.7	200 / 13.8
8	600 / 41.1	300 / 20.7	200 / 13.8
10	600 / 41.1	300 / 20.7	200 / 13.8
12	600 / 41.1	300 / 20.7	200 / 13.8

Proof test pressure: 1.5 times the listed working pressure.

Burst pressure: 1200 psi.

This warranty shall not apply to any product which has been subject to negligence, misuse, or accident, which has been repaired or altered in any manner outside of GroovJoint's facilities or which has been used in a manner contradictory to GroovJoint's instructions or recommendations. GroovJoint shall not be responsible for design errors due to inaccurate or incomplete information supplied by Buyer or its representatives.

Effective December 1, 2013.

MATERIAL SPECIFICATIONS

Housing:

Type 316 Stainless steel to ASTM A743 CF

Rubber Gaskets:

Grade "E" EPDM (Color code: Green stripe) – good for cold & hot water up to +230°F (+110°C). Also good for services for water with acid, water with chlorine, deionized water, seawater and waste water, dilute acids, oil-free air and many chemicals.

Not recommended for petroleum oils, minerals oils, solvents and aromatic hydrocarbons.

Maximum Temperature Range: -30°F (-34°C) to +230°F (+110°C)*.

*EPDM gaskets for water services are not recommended for steam applications.

- ❑ (Option) Grade "T" Nitrile (Color code: Orange stripe) – Recommended for petroleum products, air with oil vapors, vegetable and mineral oils within the specified temperature range. Also good for water services under +150°F (+66°C). Temperature range: -20°F to +180°F (-29°C to +82°C). Do not use for HOT WATER above +150°F (+66°C) or HOT DRY AIR above +140°F (+60°C)

Bolts & Nuts:

Type 304 Stainless steel track bolts to A193 B-8 with heavy-duty nuts to ASTM A194 B8.

STAINLESS STEEL SYSTEMS

www.pipingnow.com

Rigid Couplings part #24

Standard Weight Rigid Coupling with "C" Gasket

Maximum working pressure depending on schedule of pipe:

1-1/2"-12" Sch.10 stainless steel pipe 300psi (20.7bar)
1-1/2"-12" Sch. 40 stainless steel pipe 600psi (41.1bar)

Gasket Grade E-EPDM (green stripe) -30F to 230F Gasket
Grade T-Nitrile (orange stripe) -20F to 180F

UL 213 Tested and Approved and NSF 61 Approved

Stainless Steel Couplings conform to ASTM A743/A743M

Bolts conform to ASTM A193M Class 2, Type 304 B8M

Stainless Steel Nuts are hex nuts conform to ASTM A 194M
Type 304

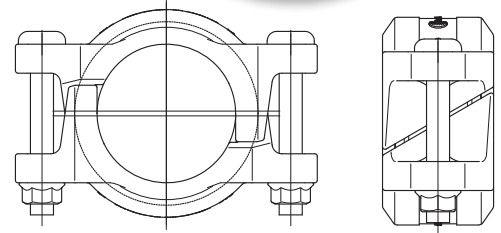

Pipe Size		Max. † Pressures psi (bar)	Nominal Dimensions			Coupling Bolts	
Nominal ANSI Inches DN	O.D. Inches mm		A Inches mm	B Inches mm	C Inches mm	Qty.	Size** Inches
1-1/2	1.900	600	2.83	4.29	1.81	2	3/8
DN40	(48.3)	(42.0)	(72.0)	(109.0)	(46.0)		
2	2.375	600	3.41	5.12	1.88	2	3/8
DN50	(60.3)	(41.4)	(86.6)	(130.0)	(47.8)		
2-1/2	2.875	600	3.91	5.63	1.88	2	3/8
DN65	(73.0)	(41.4)	(99.3)	(143.0)	(47.8)		
3	3.500	600	4.63	6.25	1.88	2	3/8
DN80	(88.9)	(41.4)	(117.6)	(158.8)	(47.8)		
4	4.500	600	5.81	7.50	1.97	2	3/8
DN100	(114.3)	(41.4)	(147.6)	(190.5)	(50.0)		
5	5.563	600	7.09	9.71	2.04	2	1/2
DN125	(141.3)	(41.4)	(180.1)	(246.6)	(51.8)		
6	6.625	600	8.09	10.53	2.13	2	1/2
DN150	(168.3)	(41.4)	(205.5)	(267.5)	(54.1)		
8	8.625	600	10.56	13.56	2.62	2	5/8
DN200	(219.1)	(41.4)	(268.2)	(344.4)	(66.5)		
10	10.750	600	12.84	16.41	2.62	2	7/8
DN250	(273.0)	(41.4)	(326.1)	(416.8)	(66.5)		
12	12.750	600	15.41	18.84	2.62	2	7/8
DN300	(323.9)	(41.4)	(391.4)	(478.5)	(66.5)		



Other Gasket styles are available upon request.



Tested and Certified to
UL 213 Standards



Certified to
NSF/ANSI 61-G

GroovJoint reserves the right to change the contents without notice.

STAINLESS STEEL SYSTEMS

www.pipingnow.com

Flexible Couplings model 15

Standard Weight Flexible Coupling with "C" Gasket

Maximum working pressure depending on schedule of pipe:

1"-8" Sch.10 pipe 300psi (20.7 bar)
1"-8" Sch. 40 pipe 600psi (41.1 bar)

NSF61 Approved

Gasket Grade E – EPDM (green stripe) -30°F to +230°F
Gasket Grade T – Nitrile (orange stripe) -20°F to +180°F

Stainless Steel Couplings conform to ASTM A743/A743M
Bolts conform to ASTM A193M Class 2,

Type 304 Grade B8M
Stainless Steel Nuts are hex nuts conforming to
ASTM A 194M Type 304, Grade 8M

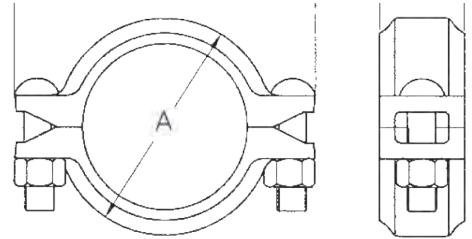
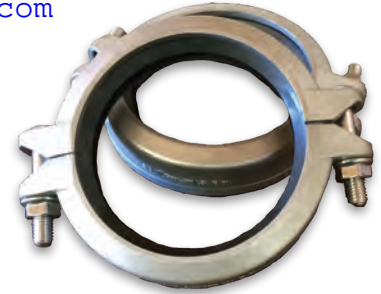

Pipe Size		Max. Working Pressure (CWP) psi (bar)	Nominal Dimensions			Coupling Bolt Size Inches	Weight Lbs Kgs
Nominal Size Inches DN	O.D. Inches mm		A Inches mm	B Inches mm	C Inches mm		
1	1.315	600	2.19	3.45	1.73	3/8	1.1
25	33.4	41.1	55.7	87.5	44.0		0.5
1-1/4	1.660	500	2.54	3.85	1.73	5/16	1.1
32	42.2	35	64.6	97.8	44.0		0.5
1-1/2	1.900	600	2.79	4.14	1.73	3/8	1.1
40	48.3	41.1	70.8	105.1	44.0		0.5
2	2.375	600	3.28	4.88	1.73	3/8	1.5
50	60.3	41.1	83.0	124.0	44.0		0.7
3	3.500	600	4.39	6.18	1.73	3/8	2.2
80	88.9	41.1	111.0	157.0	44.0		1.0
4	4.500	600	5.62	7.87	1.97	3/8	3.7
100	114.3	41.1	143.0	200.0	50.0		1.7
6	6.625	600	7.80	9.96	2.09	1/2	6.4
150	168.3	41.1	198.0	253.1	53.0		2.9
8	8.625	600	10.04	13.27	2.44	5/8	14.1
200	219.1	41.1	255.0	337.0	62.0		6.4



Certified to
NSF/ANSI 61-G

GroovJoint reserves the right to change the contents without notice.



MATERIAL SPECIFICATIONS

- Fitting Body:
 - ❑ Fabricated Fittings: 1"-12" 304L/316L stainless steel conforming to ASTM A403 WPW or A403CR, Schedule 10 and Schedule 40
 - ❑ Full Flow Fittings: 1"-12" 304L/316L stainless steel conforming to A403 WPW or A403CR, Schedule 10 and Schedule 40
 - ❑ Sizes 14" and above in 304L/ 316L stainless steel conform to A774 or A403CR or A403WPW Schedule 10
- Fittings are available in full flow and fabricated versions in 304L and 316L.

MAXIMUM WORKING PRESSURE

- Pressure ratings for the stainless steel fitting are equal to the pressure rating of the coupling that is installed on stainless steel pipe with equal wall thickness.

GENERAL NOTES

- Pressure Ratings for fittings conform to the working pressure of the coupling used to join the system.
- Listed and or Approved Pressures are pressure ratings for fire protection systems, tested and approved by various approval bodies.
- Field Joint Test: For one time only the system may be tested hydrostatically at 1½times the maximum working pressure listed (AWWA C606 5.2.3).
- Warning: Piping systems must always be depressurized and drained before attempting disassembly and or removal of any components.
- GroovJoint reserves the right to change specifications, designs and or standard without notice and without incurring any obligations.

Job Name:	System No.	Location:
Contractor:	Approved:	
Engineer:	Approved:	

GroovJoint product specifications in U.S. customary units and metric are approximate and are provided for reference only. GroovJoint reserves the right to change or modify product design, construction, specifications, or materials without prior notice and without incurring any obligations to make such changes and modifications on GroovJoint products previously subsequently sold.

STAINLESS STEEL SYSTEMS

www.pipingnow.com

Galvanized Rigid Couplings

Ducco GT 4020

- 60° angle pad design
- Resists flexural and torsion load
- Listed pressure is maximum working pressure; for the fire protection application, approved pressure by related authorities should be used

UL/ULC: 300PSI

FM: 300PSI

- Couplings come with EPDM Gaskets as standard; nitrile gaskets are available upon request
- Manufactured by DUCCO Industries; sold by GroovJoint

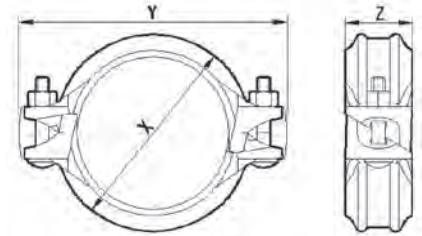

Pipe	Coupling Dimensions			Bolt		Max. Working Pressure psi	Approx. Weight each lbs/kgs	Allowable Pipe End Separation Inches mm
Size Inches mm	X Inches mm	Y Inches mm	Z Inches mm	No.	Size x Length Inches mm			
1	2.17	3.86	1.77	2	3/8 x 2	750	1.3	0.09
25	55	98	45		M10x50			
1-1/4	2.36	4.21	1.77	2	3/8 x 2	750	1.3	0.09
32	60	107	45		M10x50			
1-1/2	2.80	4.49	1.77	2	3/8 x 2	750	1.4	0.09
40	71	114	45		M10x50			
2	3.35	5.04	1.77	2	3/8 x 2	750	1.8	0.09
50	85	128	45		M10x50			
2-1/2	3.94	5.79	1.89	2	3/8 x 2-1/4	750	2.4	0.11
65	100	147	48		M10x55			
3	4.45	6.34	1.89	2	3/8 x 2-1/4	750	2.6	0.11
80	113	161	48		M10x55			
4	5.63	7.68	2.09	2	3/8 x 2-1/2	750	3.5	0.19
100	143	195	53		M10x60			
5	6.77	9.06	2.09	2	1/2 x 3	750	5.1	0.19
125	172	230	53		M12x75			
6	7.87	10.43	2.13	2	1/2 x 3	750	6.0	0.19
150	200	265	54		M12x75			
8	10.24	13.94	2.32	2	3/4 x 4-1/4	600	10.4	0.23
200	260	354	59		M20x110			
10	12.4	15.98	2.48	2	3/4 x 4-1/4	600	13.2	0.25
250	315	406	63		M20x110			
12	14.49	18.19	2.52	2	3/4 x 4-1/4	600	17.6	0.25
300	368	462	64		M20x110			

GroovJoint reserves the right to change the contents without notice.



MATERIAL SPECIFICATIONS

- Fitting Body:
 - ❑ Fabricated Fittings: 1"-12" 304L/316L stainless steel conforming to ASTM A403 WPW or A403CR, Schedule 10 and Schedule 40
 - ❑ Full Flow Fittings: 1"-12" 304L/316L stainless steel conforming to A403 WPW or A403CR, Schedule 10 and Schedule 40
 - ❑ Sizes 14" and above in 304L/ 316L stainless steel conform to A774 or A403CR or A403WPW Schedule 10
- Fittings are available in full flow and fabricated versions in 304L and 316L.

MAXIMUM WORKING PRESSURE

- Pressure ratings for the stainless steel fitting are equal to the pressure rating of the coupling that is installed on stainless steel pipe with equal wall thickness.

GENERAL NOTES

- Pressure Ratings for fittings conform to the working pressure of the coupling used to join the system.
- Listed and or Approved Pressures are pressure ratings for fire protection systems, tested and approved by various approval bodies.
- Field Joint Test: For one time only the system may be tested hydrostatically at 1½times the maximum working pressure listed (AWWA C606 5.2.3).
- Warning: Piping systems must always be depressurized and drained before attempting disassembly and or removal of any components.
- GroovJoint reserves the right to change specifications, designs and or standard without notice and without incurring any obligations.

Job Name:	System No.	Location:
Contractor:	Approved:	
Engineer:	Approved:	

GroovJoint product specifications in U.S. customary units and metric are approximate and are provided for reference only. GroovJoint reserves the right to change or modify product design, construction, specifications, or materials without prior notice and without incurring any obligations to make such changes and modifications on GroovJoint products previously subsequently sold.

STAINLESS STEEL, FULL-FLOW GROOVED FITTINGS

GENERAL DESCRIPTION

GroovJoint Stainless Steel, Full-Flow Grooved fittings are made of lightweight, corrosion-resistant Type 304L and 316L stainless steel. The assortment of available fittings provides economical and efficient methods to change direction in, add outlets to, reduce, or cap piping systems.

WARNING

Never remove any piping component or correct or modify any piping deficiencies without first depressurizing and draining the system. Failure to do so may result in serious personal injury, property damage, and/or impaired device performance.

It is the Designer's responsibility to select products suitable for the intended service and to ensure that pressure ratings and performance data are not exceeded. Material and gasket selection should be verified for compatibility with the specific application. Always read and understand the installation instructions.

The **GroovJoint** Grooved Fittings described herein must be installed and maintained in compliance with this document, in addition to the standards of any authorities having jurisdiction. Failure to do so may result in serious personal injury or impair the performance of these devices.

Owners are responsible for maintaining their mechanical system and devices in proper operating condition. The installing contractor or device manufacturer should be contacted with any questions.

TECHNICAL DATA

Approvals: UL, ULC, NSF61-G

Maximum Working Pressure: See specific data sheet for rating of coupling in use.

Material: Type 304L or Type 316L Stainless Steel conforming to ASTM A 403 WPW or ASTM A 403 CR. Fittings are Schedule 10 wall thickness. For Schedule 40, contact your representative.

TERMS & CONDITIONS OF SALE

These terms and conditions shall apply to any purchase order or sales of GroovJoint products.

No alteration, modification or waiver of these terms and conditions whether on Customer's purchase order or otherwise shall be valid unless the alteration, modification or waiver is specifically accepted in writing by an authorized representative of GroovJoint.

Designs and Terms and Conditions of Sale are subject to change without notice.

TERMS OF PAYMENT: As stated on invoice.

MINIMUM INVOICE CHARGES: \$50.00 for any single order.

SHIPPING TERMS: F.O.B. shipping point- freight prepaid and allowed on single orders having a net price value of \$7500 or more, for shipment at one time to one destination, as determined by GroovJoint within the continental United States, excluding Alaska, Hawaii, Puerto Rico and U.S. possessions.

Shipping on orders less than net price value of \$7500, F.O.B. shipping point will be paid by the customer. The cost of any special packaging or handling that has been requested by the customer, and is not part of our normal handling methods, will be added to the order and paid by the customer.

GroovJoint will make every effort to ship by the scheduled delivery date, but reserves the right to ship within a reasonable period thereafter. **GroovJoint shall not be held liable for any kind of damages, including but not limited to incidental or consequential damages for lost revenue or lost sales or liquidated damages, directly or indirectly arising from delays or failure to meet shipping dates.**

Orders, when accepted, cannot be cancelled without our written consent. No material will be taken back without our written consent. **Orders for non-standard (i.e. non-cancellable/non-returnable) material may not be cancelled nor will GroovJoint accept return of such material for credit.**

Claims for corrections must be made within 10 days of receipt of goods. Carriers are responsible for goods lost, damaged or delayed in transit. For your own protection, have Transportation Company's agent verify damages, shortages or delays and note them on freight bill.

WARRANTY

We warrant all products to be free from defects in materials and workmanship under normal conditions of use and service. Our obligation under this warranty is limited to repairing or replacing at our option at our factory any product which shall within one year after delivery to original buyer be returned with transportation charges prepaid, and which our



examination shall show to our satisfaction to have been defective.

THIS WARRANTY IS MADE EXPRESSLY IN LIEU OF ANY OTHER WARRANTIES, EXPRESS OR IMPLIED, INCLUDING ANY IMPLIED WARRANTY OF MERCHANTABILITY OR FITNESS FOR A PARTICULAR PURPOSE. THE BUYER'S SOLE AND EXCLUSIVE REMEDY SHALL BE FOR THE REPAIR OR REPLACEMENT OF DEFECTIVE PRODUCTS AS PROVIDED HEREIN. THE BUYER AGREES THAT NO OTHER REMEDY (INCLUDING, BUT NOT LIMITED TO, INCIDENTAL OR CONSEQUENTIAL DAMAGES FOR LOST PROFITS, LOST SALES, INJURY TO PERSON OR PROPERTY OR ANY OTHER INCIDENTAL OR CONSEQUENTIAL LOSS) SHALL BE AVAILABLE TO HIM.

GroovJoint neither assumes nor authorizes any person to assume for it any other liability in connection with the sale of such products.

This warranty shall not apply to any product which has been subject to negligence, misuse, or accident, which has been repaired or altered in any manner outside of GroovJoint's facilities or which has been used in a manner contradictory to GroovJoint's instructions or recommendations. GroovJoint shall not be responsible for design errors due to inaccurate or incomplete information supplied by Buyer or its representatives.

Effective December 1, 2013.

STAINLESS STEEL SYSTEMS

www.pipingnow.com

90° Elbows

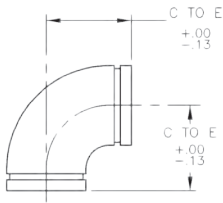

part #469

Pipe Size		C to E Inches mm	Approx. Weight Lbs. kg
Nominal Inches mm	O.D. Inches mm		
1	1.315	2.88	1.0
25	33.4	73.2	0.45
1-1/4	1.660	3.13	1.0
32	42.4	79.5	0.45
1-1/2	1.900	3.50	1.0
40	48.3	88.9	0.45
2	2.375	4.50	1.1
50	60.3	114.3	0.50
2-1/2	2.875	5.00	1.7
65	73.0	127.0	0.77
3	3.500	4.50	2.6
80	88.9	114.3	1.18
4	4.500	6.00	4.7
100	114.3	152.4	2.13
5	5.563	7.50	8.4
125	141.3	190.5	3.81
6	6.625	9.00	10.3
150	168.3	228.6	4.67
8	8.625	12.00	17.6
200	219.1	304.8	7.98
10	10.750	15.00	49.2
250	273.0	381.0	22.32
12	12.750	18.00	78.4
300	323.9	457.2	35.56

45° Elbows

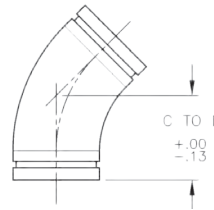

part #464

Pipe Size		C to E Inches mm	Approx. Weight Lbs. kg
Nominal Inches mm	O.D. Inches mm		
1	1.315	2.00	0.6
25	33.4	50.8	0.27
1-1/4	1.660	2.00	0.8
32	42.4	50.8	0.36
1-1/2	1.900	2.25	1.0
40	48.3	88.9	0.45
2	2.375	2.75	1.2
50	60.3	69.9	0.54
2-1/2	2.875	2.81	1.7
65	73.0	71.4	0.77
3	3.500	2.00	1.3
80	88.9	50.8	0.59
4	4.500	2.50	2.3
100	114.3	63.5	1.04
5	5.563	3.13	4.2
125	141.3	79.4	1.90
6	6.625	3.75	5.1
150	168.3	95.3	2.31
8	8.625	5.00	13.8
200	219.1	127.0	6.26
10	10.750	6.25	24.6
250	273.0	158.8	11.16
12	12.750	7.50	39.2
300	323.9	190.5	17.78

MAXIMUM WORKING PRESSURE – See specific data sheet for rating of coupling in use.

GroovJoint reserves the right to change the contents without notice.



MATERIAL SPECIFICATIONS

- Fitting Body:
 - ❑ Fabricated Fittings: 1"-12" 304L/316L stainless steel conforming to ASTM A403 WPW or A403CR, Schedule 10 and Schedule 40
 - ❑ Full Flow Fittings: 1"-12" 304L/316L stainless steel conforming to A403 WPW or A403CR, Schedule 10 and Schedule 40
 - ❑ Sizes 14" and above in 304L/ 316L stainless steel conform to A774 or A403CR or A403WPW Schedule 10
- Fittings are available in full flow and fabricated versions in 304L and 316L.

MAXIMUM WORKING PRESSURE

- Pressure ratings for the stainless steel fitting are equal to the pressure rating of the coupling that is installed on stainless steel pipe with equal wall thickness.

GENERAL NOTES

- Pressure Ratings for fittings conform to the working pressure of the coupling used to join the system.
- Listed and or Approved Pressures are pressure ratings for fire protection systems, tested and approved by various approval bodies.
- Field Joint Test: For one time only the system may be tested hydrostatically at 1½times the maximum working pressure listed (AWWA C606 5.2.3).
- Warning: Piping systems must always be depressurized and drained before attempting disassembly and or removal of any components.
- GroovJoint reserves the right to change specifications, designs and or standard without notice and without incurring any obligations.

Job Name:	System No.	Location:
Contractor:	Approved:	
Engineer:	Approved:	

GroovJoint product specifications in U.S. customary units and metric are approximate and are provided for reference only. GroovJoint reserves the right to change or modify product design, construction, specifications, or materials without prior notice and without incurring any obligations to make such changes and modifications on GroovJoint products previously subsequently sold.

STAINLESS STEEL SYSTEMS

www.pipingnow.com

Tees

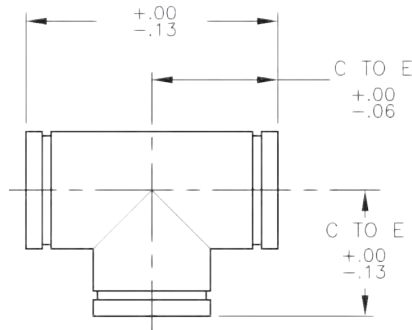

part #46T

Pipe Size		C to E Inches mm	Approx. Weight Lbs. kg
Nominal Inches mm	O.D. Inches mm		
1	1.315	2.88	1.0
25	33.4	73.2	0.45
1-1/4	1.660	3.38	1.5
32	42.4	85.9	0.68
1-1/2	1.900	3.38	1.6
40	48.3	85.9	0.73
2	2.375	2.75	2.3
50	60.3	69.9	1.04
2-1/2	2.875	3.07	2.2
65	73.0	78.0	1.00
3	3.500	3.77	3.1
80	88.9	95.8	1.41
4	4.500	4.47	4.9
100	114.3	113.5	2.22
5	5.563	5.91	7.1
125	141.3	150.1	3.49
6	6.625	5.91	11.7
150	168.3	150.1	5.31
8	8.625	7.79	20.0
200	219.1	197.9	9.07
10	10.750	8.89	34.4
250	273.0	225.8	15.60
12	12.750	10.39	52.5
300	323.9	263.9	23.81

MAXIMUM WORKING PRESSURE – See specific data sheet for rating of coupling in use.

GroovJoint reserves the right to change the contents without notice.

MATERIAL SPECIFICATIONS

- Fitting Body:
 - ❑ Fabricated Fittings: 1"-12" 304L/316L stainless steel conforming to ASTM A403 WPW or A403CR, Schedule 10 and Schedule 40
 - ❑ Full Flow Fittings: 1"-12" 304L/316L stainless steel conforming to A403 WPW or A403CR, Schedule 10 and Schedule 40
 - ❑ Sizes 14" and above in 304L/ 316L stainless steel conform to A774 or A403CR or A403WPW Schedule 10
- Fittings are available in full flow and fabricated versions in 304L and 316L.

MAXIMUM WORKING PRESSURE

- Pressure ratings for the stainless steel fitting are equal to the pressure rating of the coupling that is installed on stainless steel pipe with equal wall thickness.

GENERAL NOTES

- Pressure Ratings for fittings conform to the working pressure of the coupling used to join the system.
- Listed and or Approved Pressures are pressure ratings for fire protection systems, tested and approved by various approval bodies.
- Field Joint Test: For one time only the system may be tested hydrostatically at 1½times the maximum working pressure listed (AWWA C606 5.2.3).
- Warning: Piping systems must always be depressurized and drained before attempting disassembly and or removal of any components.
- GroovJoint reserves the right to change specifications, designs and or standard without notice and without incurring any obligations.

Job Name:	System No.	Location:
Contractor:	Approved:	
Engineer:	Approved:	

GroovJoint product specifications in U.S. customary units and metric are approximate and are provided for reference only. GroovJoint reserves the right to change or modify product design, construction, specifications, or materials without prior notice and without incurring any obligations to make such changes and modifications on GroovJoint products previously subsequently sold.

STAINLESS STEEL SYSTEMS

www.pipingnow.com

Reducing Tees

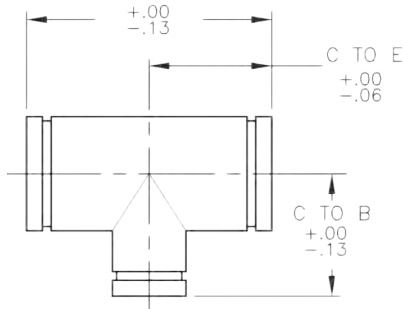

part #46RT

Pipe Size		C to E Inches mm	C to B Inches mm	Approx. Weight Lbs. kg
Nominal Inches mm	O.D. Inches mm			
1-1/2 x 1-1/2 x 1	1.900 x 1.900 x 1.315	2.75	2.75	1.6
40 x 40 x 25	48.3 x 48.3 x 33.4	85.9	85.9	0.73
1-1/2 x 1-1/2 x 1-1/4	1.900 x 1.900 x 1.660	2.75	2.75	1.6
40 x 40 x 25	48.3 x 48.3 x 42.4	85.9	85.9	0.73
2 x 2 x 1	2.375 x 2.375 x 1.315	3.25	3.25	2.2
50 x 50 x 25	60.3 x 60.3 x 33.4	82.6	69.9	1.00
2 x 2 x 1-1/4	2.375 x 2.375 x 1.660	3.25	3.25	2.4
50 x 50 x 32	60.3 x 60.3 x 42.4	82.6	82.6	1.09
2 x 2 x 1-1/2	2.375 x 2.375 x 1.900	2.75	2.75	2.4
50 x 50 x 40	60.3 x 60.3 x 48.3	69.9	69.9	1.09
2-1/2 x 2-1/2 x 1	2.375 x 2.375 x 1.315	3.75	3.75	3.1
50 x 50 x 40	60.3 x 60.3 x 33.4	95.3	95.3	1.41
2-1/2 x 2-1/2 x 1-1/2	2.375 x 2.375 x 1.900	3.75	3.75	3.4
50 x 50 x 40	60.3 x 60.3 x 48.3	95.3	95.3	1.54
2-1/2 x 2-1/2 x 2	2.375 x 2.375 x 2.375	3.07	3.07	3.6
50 x 50 x 40	60.3 x 60.3 x 60.3	78.0	78.0	1.63
3 x 3 x 1	3.500 x 3.500 x 1.315	4.25	4.25	4.3
80 x 80 x 25	88.9 x 88.9 x 33.4	108.0	108.0	1.95
3 x 3 x 1-1/4	3.500 x 3.500 x 1.660	4.25	4.25	4.3
80 x 80 x 32	88.9 x 88.9 x 42.2	108.0	108.0	1.95
3 x 3 x 1-1/2	3.500 x 3.500 x 1.900	4.25	4.25	4.4
80 x 80 x 40	88.9 x 88.9 x 48.3	108.0	108.0	2.00
3 x 3 x 2	3.500 x 3.500 x 2.375	3.77	3.23	4.4
80 x 80 x 50	88.9 x 88.9 x 60.3	95.8	82.0	2.00
3 x 3 x 2-1/2	3.500 x 3.500 x 2.875	3.77	3.23	4.4
80 x 80 x 65	88.9 x 88.9 x 73.0	95.8	82.0	2.00
4 x 4 x 2	4.500 x 4.500 x 2.375	4.47	3.82	4.4
100 x 100 x 50	114.3 x 114.3 x 60.3	113.5	97.0	2.00
4 x 4 x 2-1/2	4.500 x 4.500 x 2.875	4.47	3.82	4.4
100 x 100 x 65	114.3 x 114.3 x 73.0	113.5	113.5	2.00
4 x 4 x 3	4.500 x 4.500 x 3.500	4.47	3.88	4.9
100 x 100 x 80	114.3 x 114.3 x 88.9	114.5	69.9	2.22

MAXIMUM WORKING PRESSURE – See specific data sheet for rating of coupling in use.

GroovJoint reserves the right to change the contents without notice.

STAINLESS STEEL SYSTEMS

Reducing Tees

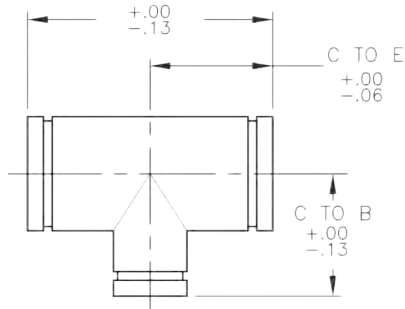

part #46RT

Pipe Size		C to E Inches mm	C to B Inches mm	Approx. Weight Lbs. kg
Nominal Inches mm	O.D. Inches mm			
6 x 6 x 1-1/2	6.625 x 6.625 x 1.900	5.91	5.91	9.3
150 x 150 x 40	168.3 x 168.3 x 48.3	150.1	150.1	4.22
6 x 6 x 2	6.625 x 6.625 x 2.375	5.91	5.91	9.3
150 x 150 x 50	168.3 x 168.3 x 88.9	150.1	150.1	4.22
6 x 6 x 3	6.625 x 6.625 x 3.500	5.91	4.88	9.3
150 x 150 x 80	168.3 x 168.3 x 60.3	150.1	124.0	4.22
6 x 6 x 4	6.625 x 6.625 x 4.500	5.91	5.12	9.3
150 x 150 x 100	168.3 x 168.3 x 114.3	150.1	130.0	4.22
8 x 8 x 4	8.625 x 8.625 x 4.500	7.79	6.31	18.1
200 x 200 x 100	219.1 x 219.1 x 114.1	197.9	160.3	8.21
8 x 8 x 6	8.625 x 8.625 x 6.625	7.79	6.62	18.1
200 x 200 x 150	219.1 x 219.1 x 168.3	197.9	168.1	8.21
10 x 10 x 6	10.750 x 10.750 x 6.625	8.89	7.70	29.3
250 x 250 x 200	273.0 x 273.0 x 168.3	225.8	195.6	13.29
10 x 10 x 8	10.750 x 10.750 x 8.625	8.89	8.59	31.7
250 x 250 x 200	273.0 x 273.0 x 219.1	225.8	218.2	14.38
12 x 12 x 8	12.750 x 12.750 x 8.625	10.39	9.51	44
300 x 300 x 200	323.9 x 323.9 x 219.1	263.9	242.0	19.96
12 x 12 x 10	12.750 x 12.750 x 10.750	10.39	9.89	44
300 x 300 x 250	323.9 x 323.9 x 273.0	263.9	251.2	19.96

MAXIMUM WORKING PRESSURE – See specific data sheet for rating of coupling in use.

GroovJoint reserves the right to change the contents without notice.



MATERIAL SPECIFICATIONS

- Fitting Body:
 - ❑ Fabricated Fittings: 1"-12" 304L/316L stainless steel conforming to ASTM A403 WPW or A403CR, Schedule 10 and Schedule 40
 - ❑ Full Flow Fittings: 1"-12" 304L/316L stainless steel conforming to A403 WPW or A403CR, Schedule 10 and Schedule 40
 - ❑ Sizes 14" and above in 304L/ 316L stainless steel conform to A774 or A403CR or A403WPW Schedule 10
- Fittings are available in full flow and fabricated versions in 304L and 316L.

MAXIMUM WORKING PRESSURE

- Pressure ratings for the stainless steel fitting are equal to the pressure rating of the coupling that is installed on stainless steel pipe with equal wall thickness.

GENERAL NOTES

- Pressure Ratings for fittings conform to the working pressure of the coupling used to join the system.
- Listed and or Approved Pressures are pressure ratings for fire protection systems, tested and approved by various approval bodies.
- Field Joint Test: For one time only the system may be tested hydrostatically at 1½times the maximum working pressure listed (AWWA C606 5.2.3).
- Warning: Piping systems must always be depressurized and drained before attempting disassembly and or removal of any components.
- GroovJoint reserves the right to change specifications, designs and or standard without notice and without incurring any obligations.

Job Name:	System No.	Location:
Contractor:	Approved:	
Engineer:	Approved:	

GroovJoint product specifications in U.S. customary units and metric are approximate and are provided for reference only. GroovJoint reserves the right to change or modify product design, construction, specifications, or materials without prior notice and without incurring any obligations to make such changes and modifications on GroovJoint products previously subsequently sold.

STAINLESS STEEL SYSTEMS

Grooved by Press Reducing Tees

www.pipingnow.com

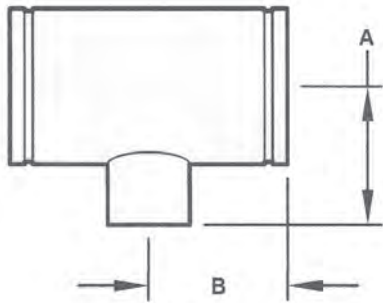

part #46RT

Pipe Size		C to A Inches mm	C to B Inches mm	Approx. Weight Lbs. kg
Nominal Inches mm	O.D. Inches mm			
2-1/2 x 2-1/2 x 1-1/2	2.875 x 1.900 x 2.875	3.75	4.10	3.40
65 x 40 x 65	73.0 x 48.3 x 73.0	95.3	104.1	1.54
2-1/2 x 2-1/2 x 2	2.875 x 2.375 x 2.875	3.75	4.60	3.60
65 x 50 x 65	73.0 x 60.3 x 73.0	95.3	116.6	1.63
3 x 3 x 1	3.500 x 1.315 x 3.500	4.25	4.20	4.30
80 x 25 x 80	88.9 x 33.4 x 88.9	108.0	106.7	1.95
3 x 3 x 1-1/2	3.500 x 1.900 x 3.500	4.25	4.50	4.40
80 x 40 x 80	88.9 x 48.3 x 88.9	108.0	111.9	2.00
3 x 3 x 2	3.500 x 3.500 x 2.375	4.25	5.00	4.40
80 x 50 x 80	88.9 x 88.9 x 60.3	108.0	125.0	2.00
4 x 4 x 1	4.500 x 4.500 x 1.315	4.47	5.50	4.50
100 x 25 x 100	114.3 x 114.3 x 33.4	113.5	139.7	2.02
4 x 4 x 2	4.500 x 2.375 x 4.500	4.47	5.50	4.50
100 x 50 x 100	114.3 x 60.3 x 114.3	113.5	139.7	2.02
6 x 6 x 1	6.625 x 6.625 x 1.315	5.91	6.00	9.20
150 x 25 x 150	168.3 x 163.3 x 33.4	150.1	152.4	4.22
6 x 6 x 1-1/2	6.625 x 1.900 x 6.625	5.91	6.00	9.20
150 x 40 x 150	168.3 x 48.3 x 168.3	150.1	152.4	4.22
6 x 6 x 2	6.625 x 2.375 x 6.625	5.91	6.50	9.40
150 x 50 x 150	168.3 x 60.3 x 168.3	150.1	165.0	4.26

MAXIMUM WORKING PRESSURE – See specific data sheet for rating of coupling in use.

GroovJoint reserves the right to change the contents without notice.



MATERIAL SPECIFICATIONS

- Fitting Body:
 - ❑ Fabricated Fittings: 1"-12" 304L/316L stainless steel conforming to ASTM A403 WPW or A403CR, Schedule 10 and Schedule 40
 - ❑ Full Flow Fittings: 1"-12" 304L/316L stainless steel conforming to A403 WPW or A403CR, Schedule 10 and Schedule 40
 - ❑ Sizes 14" and above in 304L/ 316L stainless steel conform to A774 or A403CR or A403WPW Schedule 10
- Fittings are available in full flow and fabricated versions in 304L and 316L.

MAXIMUM WORKING PRESSURE

- Pressure ratings for the stainless steel fitting are equal to the pressure rating of the coupling that is installed on stainless steel pipe with equal wall thickness.

GENERAL NOTES

- Pressure Ratings for fittings conform to the working pressure of the coupling used to join the system.
- Listed and or Approved Pressures are pressure ratings for fire protection systems, tested and approved by various approval bodies.
- Field Joint Test: For one time only the system may be tested hydrostatically at 1½times the maximum working pressure listed (AWWA C606 5.2.3).
- Warning: Piping systems must always be depressurized and drained before attempting disassembly and or removal of any components.
- GroovJoint reserves the right to change specifications, designs and or standard without notice and without incurring any obligations.

Job Name:	System No.	Location:
Contractor:	Approved:	
Engineer:	Approved:	

GroovJoint product specifications in U.S. customary units and metric are approximate and are provided for reference only. GroovJoint reserves the right to change or modify product design, construction, specifications, or materials without prior notice and without incurring any obligations to make such changes and modifications on GroovJoint products previously subsequently sold.

STAINLESS STEEL SYSTEMS

www.pipingnow.com

Concentric Reducers

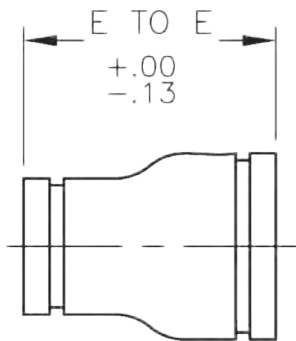

part #46C

Nominal Inches mm	Pipe Size		E to E Inches mm	Approx. Weight Lbs. kg
		O.D. Inches mm		
1-1/2 x 1	1.900 x 1.315		3.75	1.4
40 x 25	48.3 x 33.7		95.3	0.64
1-1/2 x 1-1/4	1.900 x 1.660		3.75	1.4
40 x 32	48.3 x 42.4		95.3	0.64
2 x 1	2.375 x 1.315		3.75	1.5
50 x 25	60.3 x 33.7		95.3	0.68
2 x 1-1/4	2.375 x 1.660		3.75	2.5
50 x 32	60.3 x 42.4		95.3	1.13
2 x 1-1/2	2.375 x 1.900		5.00	2.5
50 x 40	60.3 x 48.3		127.0	1.13
2-1/2 x 1-1/2	2.875 x 1.900		5.00	3.5
65 x 40	73.3 x 48.3		127.0	1.59
2-1/2 x 2	2.875 x 2.375		5.00	3.5
65 x 50	73.0 x 60.3		127.0	1.59
3 x 1	3.500 x 1.315		5.00	4.0
80 x 25	88.9 x 33.7		127.0	1.81
3 x 1-1/4	3.500 x 1.660		5.00	4.3
80 x 32	88.9 x 42.4		127.0	1.95
3 x 1-1/2	3.500 x 1.900		5.00	4.4
80 x 40	88.9 x 48.3		127.0	2.00
3 x 2	3.500 x 2.375		5.00	4.8
80 x 50	88.9 x 60.3		127.0	2.17
3 x 2-1/2	3.500 x 2.875		5.00	4.8
80 x 65	88.9 x 73.0		127.0	2.17
4 x 2	4.500 x 2.375		5.00	4.8
100 x 50	114.3 x 60.3		127.0	2.17
4 x 2-1/2	4.500 x 2.875		5.00	4.8
100 x 65	114.3 x 73.0		127.0	2.17
4 x 3	4.500 x 3.500		5.00	5.0
100 x 80	114.3 x 88.9		127.0	2.27
5 x 3	5.563 x 3.500		9.00	7.0
125 x 80	141.3 x 88.9		228.6	3.18
5 x 4	5.563 x 4.500		9.00	7.0
125 x 100	141.3 x 114.3		228.6	3.18

MAXIMUM WORKING PRESSURE – See specific data sheet for rating of coupling in use.

GroovJoint reserves the right to change the contents without notice.

STAINLESS STEEL SYSTEMS

www.pipingnow.com

Concentric Reducers

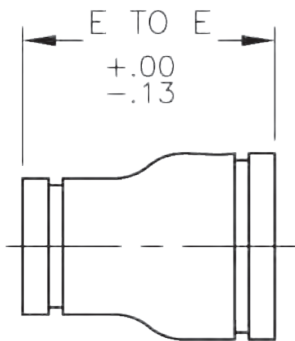

part #46C

Nominal Inches mm	Pipe Size	E to E Inches mm	Approx. Weight Lbs. kg
	O.D. Inches mm		
6 x 2	6.625 x 2.375	5.50	7.0
150 x 50	168.3 x 60.3	228.6	3.18
6 x 2-1/2	6.625 x 2.875	5.50	7.0
150 x 65	168.3 x 73.0	381.0	3.18
6 x 3	6.625 x 3.500	5.50	6.9
150 x 100	168.3 x 88.9	139.7	3.13
6 x 4	6.625 x 4.500	5.50	7.0
150 x 100	168.3 x 114.3	139.7	3.18
6 x 5	6.625 x 5.500	5.50	7.0
150 x 125	168.3 x 141.3	139.7	3.18
8 x 4	8.625 x 4.500	6.00	9.6
200 x 100	219.1 x 114.3	152.4	4.35
8 x 6	8.625 x 6.626	6.00	9.6
200 x 150	219.1 x 168.3	152.4	4.35
10 x 4	10.750 x 4.500	10.00	12.4
250 x 100	273.0 x 114.3	254.0	5.62
10 x 6	10.750 x 6.625	7.00	12.4
250 x 150	273.0 x 168.3	177.8	5.62
10 x 8	10.750 x 8.625	7.00	14.9
250 x 200	273.0 x 219.1	177.8	6.76
12 x 6	12.750 x 6.625	14.00	22.0
300 x 150	323.9 x 168.3	355.6	9.98
12 x 8	12.750 x 8.625	14.00	22.0
300 x 200	323.9 x 219.1	355.6	9.98
12 x 10	12.750 x 10.750	14.00	26.0
300 x 250	323.9 x 273.0	355.6	11.79

MAXIMUM WORKING PRESSURE – See specific data sheet for rating of coupling in use.

GroovJoint reserves the right to change the contents without notice.



MATERIAL SPECIFICATIONS

- Fitting Body:
 - ❑ Fabricated Fittings: 1"-12" 304L/316L stainless steel conforming to ASTM A403 WPW or A403CR, Schedule 10 and Schedule 40
 - ❑ Full Flow Fittings: 1"-12" 304L/316L stainless steel conforming to A403 WPW or A403CR, Schedule 10 and Schedule 40
 - ❑ Sizes 14" and above in 304L/ 316L stainless steel conform to A774 or A403CR or A403WPW Schedule 10
- Fittings are available in full flow and fabricated versions in 304L and 316L.

MAXIMUM WORKING PRESSURE

- Pressure ratings for the stainless steel fitting are equal to the pressure rating of the coupling that is installed on stainless steel pipe with equal wall thickness.

GENERAL NOTES

- Pressure Ratings for fittings conform to the working pressure of the coupling used to join the system.
- Listed and or Approved Pressures are pressure ratings for fire protection systems, tested and approved by various approval bodies.
- Field Joint Test: For one time only the system may be tested hydrostatically at 1½times the maximum working pressure listed (AWWA C606 5.2.3).
- Warning: Piping systems must always be depressurized and drained before attempting disassembly and or removal of any components.
- GroovJoint reserves the right to change specifications, designs and or standard without notice and without incurring any obligations.

Job Name:	System No.	Location:
Contractor:	Approved:	
Engineer:	Approved:	

GroovJoint product specifications in U.S. customary units and metric are approximate and are provided for reference only. GroovJoint reserves the right to change or modify product design, construction, specifications, or materials without prior notice and without incurring any obligations to make such changes and modifications on GroovJoint products previously subsequently sold.

STAINLESS STEEL SYSTEMS

www.pipingnow.com

Eccentric Reducers

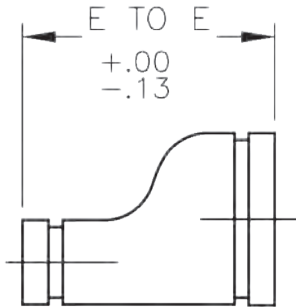

part #46E

Pipe Size		E to E Inches mm	Approx. Weight Lbs. kg
Nominal Inches mm	O.D. Inches mm		
1-1/2 x 1	1.900 x 1.315	3.75	1.4
40 x 25	48.3 x 33.7	95.3	0.64
1-1/2 x 1-1/4	1.900 x 1.660	3.75	1.4
40 x 32	48.3 x 42.4	95.3	0.64
2 x 1	2.375 x 1.315	3.75	1.5
50 x 25	60.3 x 33.7	95.3	0.68
2 x 1-1/4	2.375 x 1.660	3.75	2.5
50 x 32	60.3 x 42.4	95.3	1.13
2 x 1-1/2	2.375 x 1.900	5.00	2.5
50 x 40	60.3 x 48.3	127.0	1.13
2-1/2 x 2	2.875 x 2.375	5.00	3.5
65 x 50	73.0 x 60.3	127.0	1.59
3 x 1	3.500 x 1.315	5.00	4.3
80 x 25	88.9 x 33.7	127.0	1.95
3 x 2	3.500 x 2.375	5.00	4.3
80 x 50	88.9 x 60.3	127.0	1.95
3 x 2-1/2	3.500 x 2.875	5.00	4.5
80 x 65	88.9 x 73.0	127.0	1.95
4 x 2	4.500 x 2.375	5.00	4.8
100 x 50	114.3 x 60.3	127.0	2.18
4 x 2-1/2	4.500 x 2.875	5.00	5.8
100 x 65	114.3 x 73.0	127.0	2.63
4 x 3	4.500 x 3.500	5.00	5.9
100 x 80	114.3 x 88.9	127.0	2.68
5 x 3	5.563 x 3.500	9.00	5.9
125 x 80	141.3 x 88.9	228.6	2.68
5 x 4	5.563 x 4.500	9.00	7.0
125 x 100	141.3 x 114.3	228.6	3.18

MAXIMUM WORKING PRESSURE – See specific data sheet for rating of coupling in use.

GroovJoint reserves the right to change the contents without notice.

STAINLESS STEEL SYSTEMS

www.pipingnow.com

Eccentric Reducers

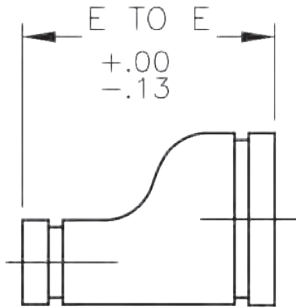

part #46E

Pipe Size		E to E Inches mm	Approx. Weight Lbs. kg
Nominal Inches mm	O.D. Inches mm		
6 x 2	6.625 x 2.375	9.00	7.0
150 x 50	168.3 x 60.3	228.6	3.18
6 x 2-1/2	6.625 x 2.875	9.00	7.0
150 x 65	168.3 x 73.0	228.6	3.18
6 x 3	6.625 x 3.500	9.00	7.0
150 x 100	168.3 x 88.9	228.6	3.18
6 x 4	6.625 x 4.500	9.00	7.0
150 x 100	168.3 x 114.3	127.7	3.18
8 x 3	8.625 x 3.500	10.00	9.3
200 x 80	219.1 x 88.9	254.0	4.22
8 x 4	8.625 x 4.500	12.00	9.3
200 x 100	219.1 x 114.3	304.8	4.22
8 x 6	8.625 x 6.625	8.00	7.0
200 x 150	219.1 x 168.3	203.2	3.18
10 x 6	10.750 x 6.625	13.00	12.4
250 x 150	273.0 x 168.3	330.2	5.62
10 x 8	10.750 x 8.625	13.00	11.5
250 x 200	273.0 x 219.1	330.2	5.22
12 x 6	12.750 x 6.625	14.00	21.1
300 x 150	323.9 x 168.3	355.6	9.57
12 x 8	12.750 x 8.625	14.00	21.1
300 x 200	323.9 x 219.1	355.6	9.57
12 x 10	12.750 x 10.750	14.00	21.1
300 250	323.9 x 273.0	355.6	9.57

MAXIMUM WORKING PRESSURE – See specific data sheet for rating of coupling in use.

GroovJoint reserves the right to change the contents without notice.



MATERIAL SPECIFICATIONS

- Fitting Body:
 - ❑ Fabricated Fittings: 1"-12" 304L/316L stainless steel conforming to ASTM A403 WPW or A403CR, Schedule 10 and Schedule 40
 - ❑ Full Flow Fittings: 1"-12" 304L/316L stainless steel conforming to A403 WPW or A403CR, Schedule 10 and Schedule 40
 - ❑ Sizes 14" and above in 304L/ 316L stainless steel conform to A774 or A403CR or A403WPW Schedule 10
- Fittings are available in full flow and fabricated versions in 304L and 316L.

MAXIMUM WORKING PRESSURE

- Pressure ratings for the stainless steel fitting are equal to the pressure rating of the coupling that is installed on stainless steel pipe with equal wall thickness.

GENERAL NOTES

- Pressure Ratings for fittings conform to the working pressure of the coupling used to join the system.
- Listed and or Approved Pressures are pressure ratings for fire protection systems, tested and approved by various approval bodies.
- Field Joint Test: For one time only the system may be tested hydrostatically at 1½times the maximum working pressure listed (AWWA C606 5.2.3).
- Warning: Piping systems must always be depressurized and drained before attempting disassembly and or removal of any components.
- GroovJoint reserves the right to change specifications, designs and or standard without notice and without incurring any obligations.

Job Name:	System No.	Location:
Contractor:	Approved:	
Engineer:	Approved:	

GroovJoint product specifications in U.S. customary units and metric are approximate and are provided for reference only. GroovJoint reserves the right to change or modify product design, construction, specifications, or materials without prior notice and without incurring any obligations to make such changes and modifications on GroovJoint products previously subsequently sold.

STAINLESS STEEL SYSTEMS

www.pipingnow.com

End Caps

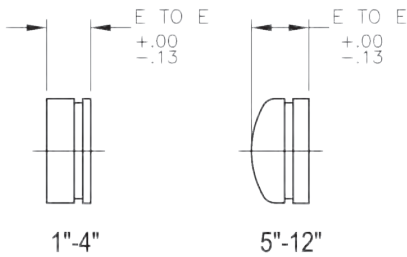

part #46CAP

*Dished cap

Pipe Size		Nominal E to E Inches mm	Approx. Weight Lbs. kg
Nominal Inches mm	O.D. Inches mm		
1	1.315	1.083	.2
25	33.4	27.5	0.09
1-1/4	1.660	1.083	.4
32	42.4	27.5	0.09
1-1/2	1.900	1.083	.5
40	48.3	27.5	0.09
2	2.375	1.083	.7
50	60.3	27.5	0.09
2-1/2	2.875	1.083	1.0
65	73.0	27.5	0.45
3	3.500	1.083	2.0
80	88.9	27.5	0.91
4	4.500	1.25	3.1
100	114.3	28.7	1.41
5	5.563	3.00*	1.5
125	141.3	76.2	0.68
6	6.625	3.50*	1.5
150	168.3	88.9	0.68
8	8.625	4.00*	3.1
200	219.1	101.6	1.41
10	10.750	5.00*	6.0
250	273.0	127.0	2.72
12	12.750	6.00*	7.8
300	323.9	152.4	3.54

MAXIMUM WORKING PRESSURE – See specific data sheet for rating of coupling in use.

GroovJoint reserves the right to change the contents without notice.



MATERIAL SPECIFICATIONS

- Fitting Body:
 - ❑ Fabricated Fittings: 1"-12" 304L/316L stainless steel conforming to ASTM A403 WPW or A403CR, Schedule 10 and Schedule 40
 - ❑ Full Flow Fittings: 1"-12" 304L/316L stainless steel conforming to A403 WPW or A403CR, Schedule 10 and Schedule 40
 - ❑ Sizes 14" and above in 304L/ 316L stainless steel conform to A774 or A403CR or A403WPW Schedule 10
- Fittings are available in full flow and fabricated versions in 304L and 316L.

MAXIMUM WORKING PRESSURE

- Pressure ratings for the stainless steel fitting are equal to the pressure rating of the coupling that is installed on stainless steel pipe with equal wall thickness.

GENERAL NOTES

- Pressure Ratings for fittings conform to the working pressure of the coupling used to join the system.
- Listed and or Approved Pressures are pressure ratings for fire protection systems, tested and approved by various approval bodies.
- Field Joint Test: For one time only the system may be tested hydrostatically at 1½times the maximum working pressure listed (AWWA C606 5.2.3).
- Warning: Piping systems must always be depressurized and drained before attempting disassembly and or removal of any components.
- GroovJoint reserves the right to change specifications, designs and or standard without notice and without incurring any obligations.

Job Name:	System No.	Location:
Contractor:	Approved:	
Engineer:	Approved:	

GroovJoint product specifications in U.S. customary units and metric are approximate and are provided for reference only. GroovJoint reserves the right to change or modify product design, construction, specifications, or materials without prior notice and without incurring any obligations to make such changes and modifications on GroovJoint products previously subsequently sold.

STAINLESS STEEL SYSTEMS

www.pipingnow.com

Flange Adaptors

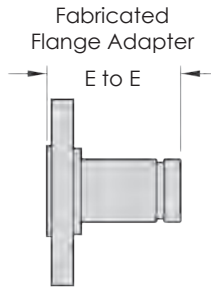

part #46F

Flange adaptors are available in both ANSI dimensions as well as PN10 and PN16

Pipe Size		E to E Inches mm	Mating Flange Bolt Qty.	Approx. Weight Lbs. kg
Nominal Inches mm	O.D. Inches mm			
1	1.315	3.00	4	2.5
25	33.4	76.2		1.1
1-1/4	1.660	4.00	4	3.8
32	42.4	101.6		1.7
1-1/2	1.900	4.00	4	4.1
40	48.3	101.6		1.9
2	2.375	4.00	4	6.0
50	60.3	101.6		2.7
2-1/2	2.875	4.00	4	9.2
65	73.0	101.6		4.2
3	3.500	4.00	4	10.4
80	88.9	101.6		4.7
4	4.500	6.00	8	19.1
100	114.3	152.2		8.7
5	5.563	6.00	8	23.0
125	141.3	152.2		10.4
6	6.625	6.00	8	29.5
150	168.3	152.2		13.4
8	8.625	6.00	8	43.5
200	219.1	152.2		19.7
10	10.750	8.00	12	68.2
250	273.0	203.2		30.9
12	12.750	8.00	12	96.1
300	323.9	203.2		43.6

MAXIMUM WORKING PRESSURE – See specific data sheet for rating of coupling in use.

GroovJoint reserves the right to change the contents without notice.



MATERIAL SPECIFICATIONS

- Fitting Body:
 - ❑ Fabricated Fittings: 1"-12" 304L/316L stainless steel conforming to ASTM A403 WPW or A403CR, Schedule 10 and Schedule 40
 - ❑ Full Flow Fittings: 1"-12" 304L/316L stainless steel conforming to A403 WPW or A403CR, Schedule 10 and Schedule 40
 - ❑ Sizes 14" and above in 304L/ 316L stainless steel conform to A774 or A403CR or A403WPW Schedule 10
- Fittings are available in full flow and fabricated versions in 304L and 316L.

MAXIMUM WORKING PRESSURE

- Pressure ratings for the stainless steel fitting are equal to the pressure rating of the coupling that is installed on stainless steel pipe with equal wall thickness.

GENERAL NOTES

- Pressure Ratings for fittings conform to the working pressure of the coupling used to join the system.
- Listed and or Approved Pressures are pressure ratings for fire protection systems, tested and approved by various approval bodies.
- Field Joint Test: For one time only the system may be tested hydrostatically at 1½times the maximum working pressure listed (AWWA C606 5.2.3).
- Warning: Piping systems must always be depressurized and drained before attempting disassembly and or removal of any components.
- GroovJoint reserves the right to change specifications, designs and or standard without notice and without incurring any obligations.

Job Name:	System No.	Location:
Contractor:	Approved:	
Engineer:	Approved:	

GroovJoint product specifications in U.S. customary units and metric are approximate and are provided for reference only. GroovJoint reserves the right to change or modify product design, construction, specifications, or materials without prior notice and without incurring any obligations to make such changes and modifications on GroovJoint products previously subsequently sold.

STAINLESS STEEL SYSTEMS

www.pipingnow.com

316 Stainless Steel Cast Flange Adaptors

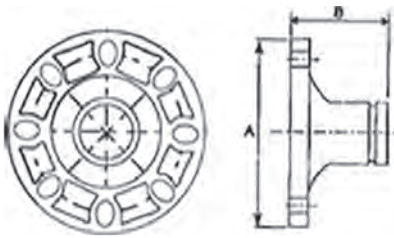

part #46FPN

Pipe Size		Flange Dimension		Max. Working Pressure PSI	Bolt Dia.	No. of Bolt Holes (Elongation)
Nominal Inches mm	O.D. Inches mm	A Inches mm	B Inches mm			
2	2.375	6.30	2.375	300	5/8	4
50	60.3	160	60.3			
2-1/2	3.000	7.125	2.375	300	5/8	4
65	76.2	181	60.3			
2-1/2	2.875	7.125	2.375	300	5/8	4
65A	73	181	60.3			
3	3.500	7.625	2.375	300	5/8	8
80	88.9	194	60.3			
4	4.500	8.625	2.375	300	5/8	8
100	114.3	219	60.3			
5	5.563	9.840	2.563	300	3/4	8
125	141.3	250	65.1			
6	6.500	11.10	2.563	300	3/4	8
150	165.1	282	65.1			
6	6.625	11.10	2.563	300	3/4	8
150A	168.3	282	65.1			
8	8.625	13.30	3.000	300	3/4	8
200	219.1	338	76.2			

Standard ANSI 150, J1S, 10K, PN16.

MAXIMUM WORKING PRESSURE – See specific data sheet for rating of coupling in use.

GroovJoint reserves the right to change the contents without notice.



MATERIAL SPECIFICATIONS

- Fitting Body:
 - ❑ Fabricated Fittings: 1"-12" 304L/316L stainless steel conforming to ASTM A403 WPW or A403CR, Schedule 10 and Schedule 40
 - ❑ Full Flow Fittings: 1"-12" 304L/316L stainless steel conforming to A403 WPW or A403CR, Schedule 10 and Schedule 40
 - ❑ Sizes 14" and above in 304L/ 316L stainless steel conform to A774 or A403CR or A403WPW Schedule 10
- Fittings are available in full flow and fabricated versions in 304L and 316L.

MAXIMUM WORKING PRESSURE

- Pressure ratings for the stainless steel fitting are equal to the pressure rating of the coupling that is installed on stainless steel pipe with equal wall thickness.

GENERAL NOTES

- Pressure Ratings for fittings conform to the working pressure of the coupling used to join the system.
- Listed and or Approved Pressures are pressure ratings for fire protection systems, tested and approved by various approval bodies.
- Field Joint Test: For one time only the system may be tested hydrostatically at 1½times the maximum working pressure listed (AWWA C606 5.2.3).
- Warning: Piping systems must always be depressurized and drained before attempting disassembly and or removal of any components.
- GroovJoint reserves the right to change specifications, designs and or standard without notice and without incurring any obligations.

Job Name:	System No.	Location:
Contractor:	Approved:	
Engineer:	Approved:	

GroovJoint product specifications in U.S. customary units and metric are approximate and are provided for reference only. GroovJoint reserves the right to change or modify product design, construction, specifications, or materials without prior notice and without incurring any obligations to make such changes and modifications on GroovJoint products previously subsequently sold.

STAINLESS STEEL SYSTEMS

Fabrication

GroovJoint manufactures a variety of stainless steel customer fabrications and specialty fittings designed to the customer's needs.

Specialty products include (but are not limited to):

- Grooved Laterals & Wyes
- Large Diameter Grooved Reducing Tees
- 3D Grooved Elbows
- Grooved Spool Pieces
- Grooved to Press and Grooved to Threaded Fittings
- Duplex and Super Duplex

Grooved fittings are available in other alloys such as Titanium, AL6XN, and Hastalloy grades.

Capabilities include:

- CNC 2 and 4 axis turning centers
- CNC horizontal and vertical machining centers
- Pickling /passivating capabilities
- Automatic Pipe Cutoff Machine
- Shotblasters
- MIG and TIG welding equipment
- Vibratory finishers
- Electropolishing

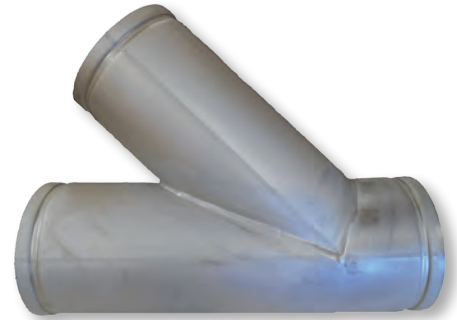

Header Construction



Stainless Steel Mixing Stations awaiting pressure testing



Grooved Piping Systems Installation Instructions





To ensure correct installation and operation of your **Groovjoint** grooved piping system, please read this manual carefully before installation, assembly or use. Keep this manual on hand for future reference.

INTRODUCTION

Thank you for selecting a **Groovjoint** product. This manual covers the proper installation and assembly procedures for your **Groovjoint** grooved piping system. To ensure the proper installation, assembly and performance of the product, read this manual thoroughly before the installation of any product and keep this manual on hand for future reference.

Groovjoint grooved couplings, flanges and grooved end fittings are manufactured for use with standard roll or cut grooves as specified in ANSI/AWWA C606 (latest edition).

General Notes

1. Always read this installation manual before installing any product.
2. Always depressurize and drain the piping system before attempting disassembly, adjustment or removal of any piping component.
3. Designers must know and understand all relevant building and or piping standards, codes and other specifications. It is the responsibility of the designer to select and or specify the appropriate products for the intended use and service.
4. Always refer to the maximum pressure rating and range of service temperatures allowed for the **Groovjoint** products and ensure that they are used within these limitations.
5. Special attention is required for selection of suitable rubber gaskets for the intended service.
6. All information and data contained herein supersedes all previous published data.
Groovjoint LLC reserves the right to change product designs and or specifications without notice and or obligation.

ABOUT ROLL-GROOVING

Roll grooving is the process of displacing pipe material without removing any of the material itself. Roll grooving is ideal for lightwall and schedule 40 pipe for sizes up thru 42" depending on the equipment used.

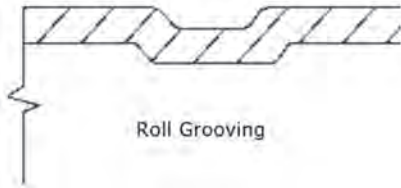

Because roll grooving removes no material from the pipe, the integrity of the pipe is not altered. The inside protrusion of a roll groove is very slight and smooth at its entry and exit points. To groove this pipe, the end is placed between a set of rollers designed for the size of pipe being grooved and then pressure is applied while the pipe is turning. Care must be taken to use the proper equipment for the piping material being used. **ALWAYS USE DIES THAT ARE DESIGNED TO ROLL GROOVE STAINLESS STEEL LIGHTWEIGHT PIPE.**

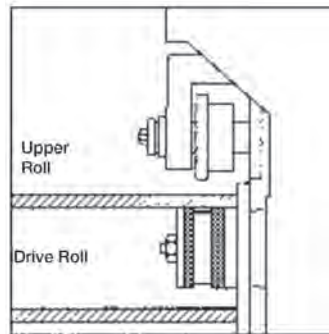

Pipe end is placed between the roll set (upper roll & drive roll)

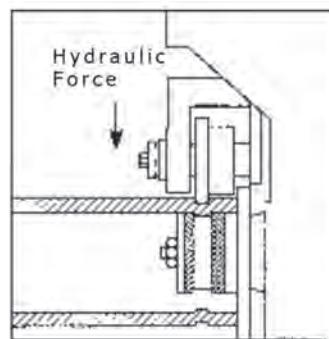

A groove is processed as the roll set is compressed and rotated

ABOUT CUT-GROOVING

The cut grooving process actually removes material from the pipe OD to form a groove. Thus cut grooving is intended for use with standard and heavier wall pipe. Most all pipes which are designed to be threaded can be cut grooved, as the depth of a cut groove is typically less than that of a standard thread. Please refer to the minimum wall thickness shown in the published standard cut groove specifications.

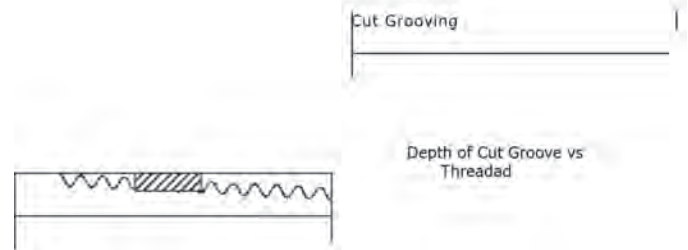

GROOVE DIMENSIONS

General Notes for Roll Groove Dimensions

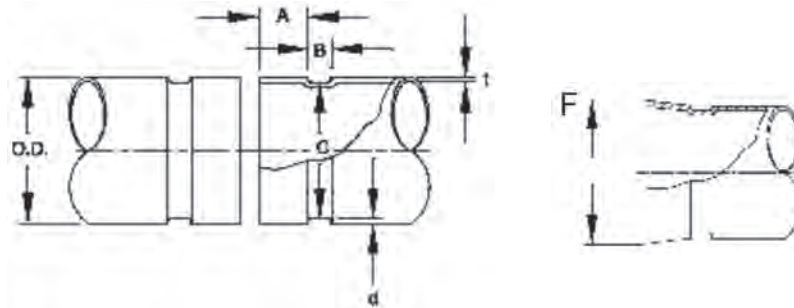

Standard Roll Groove

Nominal Size: Groovjoint couplings and fittings are identified by the nominal IPS pipe size in inches.

O.D: Pipe ends must be square cut. The maximum allowable tolerances square ends is 0.03" (0.8 mm) for sizes up to 3 1/2", 0.045" (1.2 mm) for 4" thru 6" and 0.060" (1.6 mm) for sizes 8" and above.

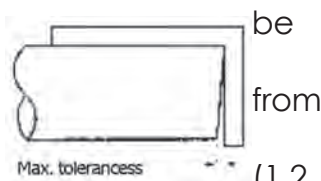

Gasket Seating Surface ("A" Dimension): The exterior surface of the gasket seating area shall be free from any indentations, projections, roll marks or other harmful surface defects such as loose paint, scale, dirt, chips, grease and rust.

Groove Width ("B" Dimension): Is to be measured between vertical flanks of the groove side walls. The corners of the groove may be rounded as long as the 'K' and "B1" values are within the maximum allowed tolerances as shown below.



Pipe Size	A	B	B1 Min.	K Max.
25 - 40 1" x 1-1/2"	15.9 ± 0.8 0.625 ± 1/16"	7.1 ± 0.8 0.281 ± 1/16"	4.1 0.161"	1.5 0.059"
50 - 150 2" - 6"	15.9 ± 0.8 0.625 ± 1/16"	8.7 ± 0.8 0.344 ± 1/16"	4.7 0.185"	2.0 0.079"
200 - 300 8" - 12"	19.0 ± 0.8 0.75 ± 1/16"	11.9 ± 0.8 0.469 ± 1/16"	7.9 0.311"	2.0 0.079"

Note: The K dimension begins where the pipe OD starts reducing and ends at the contact point with the groove ground.

To achieve optimum joint performance the "K" dimension should be as small as possible. When processing a roll groove the machine operator should manage the feed pressure of the upper roll set so as to achieve the best possible groove profile.

Groove Diameter ("C" Dimension): The groove diameters are average values. The groove must be of uniform depth around the entire pipe circumference.

Minimum Wall Thickness ("t" Dimension): The "t" is the minimum allowable wall thickness that may be roll-grooved.

Groove Depth ("d" Dimension): The values listed in the Groove Specification tables are for reference only and a slightly deeper groove may be acceptable. However, a shallower groove is never acceptable as it may lead to joint failure.

Flare Diameter ("F" Dimension): The pipe end that may flare when roll grooved shall measure within this limit when measured at the extreme end of the pipe.

Standard Roll Groove Specifications For ANSI B36.10 & Other IPS Pipe

Nominal Size mm/in	Pipe OD		A ±0.76 ±0.030	B ±0.76 ±0.030	C +0.00 +0.000	Min. Wall † mm/in	Groove Depth d (ref.) mm/in	Max. Allowed Flare Dia. F mm/in	Nominal Size mm/in
	Basic mm/in	Tolerance							
20	26.7	+0.25 -0.25	15.88	7.14	23.83 - 0.38	1.65	1.42	29.2	20
3/4	1.050	+0.010 -0.010	0.625	0.281	0.938 - 0.015	0.065	0.056	1.15	3/4
25	33.4	+0.33 -0.33	15.88	7.14	30.23 - 0.38	1.65	1.60	36.3	25
1	1.315	+0.013 -0.013	0.625	0.281	1.190 - 0.015	0.065	0.063	1.43	1
32	42.2	+0.41 -0.41	15.88	7.14	38.99 - 0.38	1.65	1.60	45.0	32
1-1/4	1.660	+0.016 -0.016	0.625	0.281	1.535 - 0.015	0.065	0.063	1.77	1-1/4
40	48.3	+0.48 -0.48	15.88	7.14	45.09 - 0.38	1.65	1.60	51.1	40
1-1/2	19.00	+0.019 -0.019	0.625	0.281	1.775 - 0.015	0.065	0.063	2.01	1-1/2
50	60.3	+0.61 -0.61	15.88	8.74	57.15 - 0.38	1.65	1.60	63.0	50
2	2.375	+0.024 -0.024	0.625	0.344	2.250 - 0.015	0.065	0.063	2.48	2
65	73.0	+0.74 -0.74	15.88	8.74	69.09 - 0.46	2.11	1.98	75.7	65
2-1/2	2.875	+0.029 -0.029	0.625	.0344	2.720 - 0.018	0.083	0.078	2.98	2-1/2
80	88.9	+0.89 -0.79	15.88	8.74	84.94 - 0.46	2.11	1.98	91.4	80
3	3.500	+0.035 -0.031	0.625	0.344	3.344 - 0.018	0.083	0.078	3.60	3
90	101.6	+1.02 -0.79	15.88	8.74	97.38 - 0.51	2.11	2.11	104.1	90
3-1/2	4.000	+0.040 -0.031	0.625	0.344	38.34 - 0.020	0.083	0.083	4.10	3-1/2
100	114.3	+1.14 -0.79	15.88	8.74	110.08 - 0.51	2.11	2.11	116.8	100
4	4.500	+0.045 -0.031	0.625	0.344	4.334 - 0.020	0.083	0.083	4.60	4
125	141.3	+1.42 -0.79	15.88	8.74	137.03 - 0.56	2.77	2.11	143.8	125
5	5.563	+0.056 -0.031	0.625	0.344	5.395 - 0.022	0.109	0.083	5.66	5
150	168.3	+1.60 -0.79	15.88	8.74	163.96 - 0.56	2.77	2.16	170.9	150
6	6.625	+0.063 -0.031	0.625	0.344	6.455 - 0.022	0.109	0.085	6.73	6
200	219.1	+1.60 -0.79	19.05	11.91	214.40 - 0.64	2.77	2.34	223.5	200
8	8.625	+0.063 -0.031	0.750	0.469	8.441 - 0.025	0.109	0.092	8.80	8
250	273.0	+1.60 -0.79	19.05	11.91	268.27 - 0.69	3.40	2.39	277.4	250
10	10.750	+0.063 -0.031	0.750	0.469	10.562 - 0.027	0.134	0.094	10.92	10
300	323.9	+1.60 -0.79	19.05	11.91	318.29 - 0.76	3.96	2.77	328.2	300
12	12.750	+0.063 -0.031	0.750	0.469	12.531 - 0.030	0.156	0.109	12.92	12
350	355.6	+1.60 -0.79	23.83	11.91	350.04 - 0.76	3.96	2.77	358.10	350
14	14.000	+0.063 -0.031	0.938	0.469	13.781 - 0.030	0.156	0.109	14.10	14
400	406.4	+1.60 -0.79	23.83	11.91	400.84 - 0.76	4.19	2.77	408.9	400
16	16.000	+0.063 -0.031	0.938	0.469	15.781 - 0.030	0.165	0.109	16.10	16
450	457.2	+1.60 -0.79	25.40	11.91	451.64 - 0.76	4.19	2.77	461.3	450
18	18.000	+0.063 -0.031	1.000	0.469	17.781 - 0.030	0.165	0.109	18.16	18
500	508.0	+1.60 -0.79	25.40	11.91	502.44 - 0.76	4.78	2.77	512.1	500
20	20.000	+0.063 -0.031	1.000	0.469	19.781 - 0.030	0.188	0.109	20.16	20
550	558.8	+1.60 -0.79	25.40	12.70	550.06 - 0.76	4.78	4.37	563.9	550
22	22.000	+0.063 -0.031	1.000	0.500	21.656 - 0.030	0.188	0.172	22.20	22
600	609.6	+1.60 -0.79	25.40	12.70	600.86 - 0.76	4.78	4.37	614.7	600
24	24.000	+0.063 -0.031	1.000	0.500	23.656 - 0.030	0.188	0.172	24.20	24

General Notes for Cut Groove Dimensions

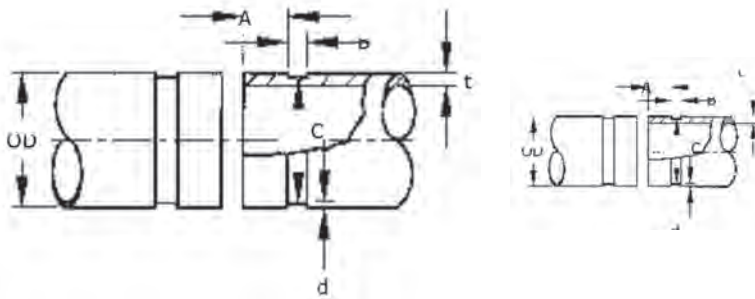

Standard Cut Groove

Nominal Size: Groovjoint couplings and fittings are identified by the nominal IPS pipe size in inches.

O.D.: Pipe ends must be square cut. The Maximum allowable tolerances from square of end is 0.03"(0.8 mm) for sizes up to 3 1/2", 0.045" (1.2 mm) for 4" thru 6" and 0.060"(1.6 mm) for sizes 8" and above.



Gasket Seating Surface ("A" Dimension): The exterior surface of the gasket seating area shall be free from any indentations, projections, roll marks or other harmful surface defects such as loose paint, scale, dirt, chips, grease and rust.

Groove Width ("B" Dimension): The groove width is to be measured between vertical flanks of the groove side walls.

Groove Diameter ("C" Dimension): The groove diameters are average values. The groove must be of uniform depth around the entire pipe circumference.

Minimum Wall Thickness ("t" Dimension): The "t" is the minimum allowable wall thickness that may be cut-grooved.

Groove Depth ("d" Dimension): The values listed in the Groove Specification tables are for reference only and a slightly deeper groove may be accept

Standard Cut Groove Specifications

For IPS / BS / DIN(ISO) / AS / JIS / KS Pipe

Nominal Size mm/in	Pipe OD		A ±0.79 ±0.031	B ±0.79 ±0.031	C +0.00 +0.000	Min. Wall † mm/in	Groove Depth d (ref.) mm/in	Nominal Size mm/in
	Basic mm/in	Tolerance						
20	26.7	+0.25 -0.25	15.88	7.95	23.83 - 0.38	2.87	1.42	20
3/4	1.050	+0.010 -0.010	0.625	0.313	0.938 - 0.015	0.113	0.056	3/4
25	33.4	+0.33 -0.33	15.88	7.95	30.23 - 0.38	3.38	1.60	25
1	1.315	+0.013 -0.013	0.625	0.313	1.190 - 0.015	0.133	0.063	1
32	42.2	+0.41 -0.41	15.88	7.95	38.99 - 0.38	3.56	1.60	32
1-1/4	1.660	+0.016 -0.016	0.625	0.313	1.535 - 0.015	0.140	0.063	1-1/4
40	48.3	+0.48 -0.48	15.88	7.14	45.09 - 0.38	3.68	1.60	40
1-1/2	19.00	+0.019 -0.019	0.625	0.281	1.775 - 0.015	0.145	0.063	1-1/2
50	60.3	+0.61 -0.61	15.88	8.74	57.15 - 0.38	3.91	1.60	50
2	2.375	+0.024 -0.024	0.625	0.344	2.250 - 0.015	0.154	0.063	2
65	73.0	+0.74 -0.74	15.88	8.74	69.09 - 0.46	4.78	1.98	65
2-1/2	2.875	+0.029 -0.029	0.625	.0344	2.720 - 0.018	0.188	0.078	2-1/2
65	76.1	+0.76 -0.76	15.88	8.74	72.26 - 0.46	4.78	1.93	65
2-1/2	3.000	+0.030 -0.030	0.625	.0344	2.845 - 0.018	0.188	0.076	2-1/2
80	88.9	+0.89 -0.79	15.88	8.74	84.94 - 0.46	4.78	1.98	80
3	3.500	+0.035 -0.031	0.625	0.344	3.344 - 0.018	0.188	0.078	3
90	101.6	+1.02 -0.79	15.88	8.74	97.38 - 0.51	4.78	2.11	90
3-1/2	4.000	+0.040 -0.031	0.625	0.344	38.34 - 0.020	0.188	0.083	3-1/2
100	108.0	+1.07 -0.79	15.88	8.74	103.73 - 0.51	5.16	2.11	100
4	4.250	+0.042 -0.031	0.625	0.344	4.084 - 0.020	0.203	0.083	4
100	114.3	+1.14 -0.79	15.88	8.74	110.08 - 0.51	5.16	2.11	100
4	4.500	+0.045 -0.031	0.625	0.344	4.334 - 0.020	0.203	0.083	4
125	133.0	+1.32 -0.79	15.88	8.74	129.13 - 0.51	5.16	1.93	125
5	5.250	+0.052 -0.031	0.625	0.344	5.084 - 0.020	0.203	0.076	5
125	139.7	+1.42 -0.79	15.88	8.74	135.48 - 0.51	5.16	2.11	125
5	5.500	+0.055 -0.031	0.625	0.344	5.334 - 0.020	0.203	0.083	5
125	141.3	+1.42 -0.79	15.88	8.74	137.03 - 0.56	5.16	2.11	125
5	5.563	+0.056 -0.031	0.625	0.344	5.395 - 0.022	0.203	0.083	5
150	159.0	+1.60 -0.79	15.88	8.74	154.50 - 0.56	5.56	2.20	150
6	6.250	+0.063 -0.031	0.625	0.344	6.080 - 0.022	0.219	0.087	6
150	165.1	+1.60 -0.79	15.88	8.74	160.80 - 0.56	5.56	2.16	150
6	6.500	+0.063 -0.031	0.625	0.344	6.330 - 0.022	0.219	0.085	6
150	168.3	+1.60 -0.79	15.88	8.74	163.96 - 0.56	5.56	2.16	150
6	6.625	+0.063 -0.031	0.625	0.344	6.455 - 0.022	0.219	0.085	6
200	216.3	+1.60 -0.79	19.05	11.91	211.60 - 0.64	6.05	2.34	200A
8	8.516	+0.063 -0.031	0.750	0.469	8.331 - 0.025	0.238	0.092	8
200	219.1	+1.60 -0.79	19.05	11.91	214.40 - 0.64	6.05	2.34	200
8	8.625	+0.063 -0.031	0.750	0.469	8.441 - 0.025	0.238	0.092	8
250	267.4	+1.60 -0.79	19.05	11.91	262.60 - 0.69	6.35	2.39	250A
10	10.528	+0.063 -0.031	0.750	0.469	10.339 - 0.027	0.250	0.094	10
250	273.0	+1.60 -0.79	19.05	11.91	268.27 - 0.69	6.35	2.39	250
10	10.750	+0.063 -0.031	0.750	0.469	10.562 - 0.027	0.250	0.094	10
300	318.5	+1.60 -0.79	19.05	11.91	312.90 - 0.76	7.09	2.77	300A
12	12.539	+0.063 -0.031	0.750	0.469	12.319 - 0.030	0.279	0.109	12
300	323.9	+1.60 -0.79	19.05	11.91	318.29 - 0.76	7.09	2.77	300
12	12.750	+0.063 -0.031	0.750	0.469	12.531 - 0.030	0.279	0.109	12
350	355.6	+1.60 -0.79	23.83	11.91	350.04 - 0.76	7.14	2.77	350
14	14.000	+0.063 -0.031	0.938	0.469	13.781 - 0.030	0.281	0.109	14
400	406.4	+1.60 -0.79	23.83	11.91	400.84 - 0.76	7.92	2.77	400
16	16.000	+0.063 -0.031	0.938	0.469	15.781 - 0.030	0.312	0.109	16
450	457.2	+1.60 -0.79	25.40	11.91	451.64 - 0.76	7.92	2.77	450
18	18.000	+0.063 -0.031	1.000	0.469	17.781 - 0.030	0.312	0.109	18
500	508.0	+1.60 -0.79	25.40	11.91	502.44 - 0.76	7.92	2.77	500
20	20.000	+0.063 -0.031	1.000	0.469	19.781 - 0.030	0.312	0.109	20
550	558.8	+1.60 -0.79	25.40	12.70	550.06 - 0.76	9.53	4.37	550
22	22.000	+0.063 -0.031	1.000	0.500	21.656 - 0.030	0.375	0.172	22
600	609.6	+1.60 -0.79	25.40	12.70	600.86 - 0.76	9.53	4.37	600
24	24.000	+0.063 -0.031	1.000	0.500	23.656 - 0.030	0.375	0.172	24

BOLTS & NUTS

Bolt Torque for Proper Assembly of Couplings

Groovjoint pipe couplings are always supplied with factory bolts and nuts. Always use factory supplied bolts and nuts for assembly of **Groovjoint** pipe couplings. Shown below are required torque ranges for proper installation with factory supplied bolts and nuts. These are not maximum torques, though never exceed the listed torque values by more than 25%, as excessive torque could lead to bolt or joint failure. Always tighten nuts evenly and equally by alternating sides to prevent the gasket from being pinched. Pinching of gasket may cause an immediate or delayed leak.

These torque range values can be used for setting the torque on power drivers.

Stainless Steel Track Bolts

Bolt Size		Torque Range	
mm	inch	N - m	Lbs - ft
M8	5/16	8 - 15	6 - 11
M10	3/8	17 - 25	12 - 18
M12	1/2	35 - 60	25 - 45
M16	5/8	68 - 100	50 - 75
M20	3/4	85 - 200	65 - 150
M22	7/8	145 - 235	105 - 175

RUBBER GASKETS

Grades and Recommended Services

Groovjoint gaskets are engineered and designed to meet and exceed standards such as ASTM D2000, AWWA C606, NSF 61. Independent laboratory testing confirms this. Our continual research, development and testing are designed to advance the elastomer field and to develop new and better solutions for our ever changing industry.

Chemical resistance is primarily determined by the grade and or the compound of the gasket. The color coding identifies the gasket grade and or compound. Always verify that the gasket selected is correct for the intended service.

Service temperature is controlled by factors including the gasket compound, fluid medium (air, water, oils, etc.), and continuity (continuous or intermittent) of service. Under no circumstances should gaskets be exposed to temperatures above or below their individual ratings.

EPDM Gaskets

Compound	Grade	Color Code	Recommended Services	Maximum Temp.
EPDM	E	Green Stripe*	Good for cold & hot water up to +230°F (+110°C). Also good for services for water with acid, water with chlorine, deionized water, seawater and waste water, dilute acids, oil-free air, and many chemicals. Not recommended for petroleum oils, mineral oils, solvents, and aromatic hydrocarbons.	-30°F (-34°C) to +230°F (+110°C)

INSTALLATION INSTRUCTIONS – GROOVED COUPLINGS

Gasket Installation – Preliminary Steps

- 1. INSPECT PIPE ENDS:** For optimum sealing by the gasket, the exterior surface of the pipe ends must be free from any indentations, projections, roll marks or other harmful surface defects such as loose paint, scale, dirt, chips, grease and rust.
- 2. CHECK GASKET:** Verify the gasket supplied is correct for the intended service. Color code identifies gasket grade.
- 3. LUBRICATE GASKET:** To help insert pipe and mount couplings smoothly without pinching, apply a thin layer of Lubricant to the sealing lips of the gasket and as well as to the exterior of the gasket.
- 4. INSTALL GASKET:** Install the gasket over one end of the pipe so that the pipe end is exposed. No part of the gasket should overhang this end of the pipe.
- 5. BRING THE MATING PIPE TOGETHER:** Bring together and align the two pipe ends to be joined. Slide the gasket over the ends and center it between the grooves of the pipe to be joined. No part of the gasket should protrude into the groove of either pipe.
- 6. ASSEMBLE COUPLING:** For a “swing-over” assembly loosely install one bolt and nut on one side of the coupling. For a standard assembly start with the two housings separated.
- 7. INSTALL COUPLING HALVES:** For a “swing-over” installation, place one of the coupling halves around the bottom side of the gasket and swing over the other coupling half into position over the top side of the gasket. For a standard installation install the coupling halves one at a time. In both cases make sure the coupling keys are engaged in the grooves.
- 8. INSERT BOLT & NUT:** Insert the remaining bolt and apply the nut hand-tight. Make sure that the oval neck of the bolt engages into the bolt hole of the housing.

CAUTION

NOTE: As the coupling bolts are tightened, the angled bolt pads slide in opposite directions causing the coupling keys to tightly grip the pipe, while at the same time the pipe grooves are forced outward against the coupling keys. The bolt pads should always maintain metal-to-metal contact.



NOTES

www.pipingnow.com

Corporate Office:
155 North Wacker Drive
Suite 4250
Chicago, IL 60606
312-803-2627 – Phone
sales@GroovJoint.com
www.GroovJoint.com

Middle East Office:
Level 14, Boulevard Plaza Tower 1
Sheikh Mohammed Bin Rashid Boulevard
Downtown Dubai, PO Box 334036
Dubai, United Arab Emirates
+971 4 424 5036 – Phone
+971 4 455 8556 – Fax
sales@GroovJoint.com
www.GroovJoint.com



**"Groovjoint Products are
Manufactured by Proud
American Craftsmen"**

